

Honoré Daumier

A Centenary Tribute

Edited by Andrew Stasik

*Published by Pratt Graphics Center,
an Extension of Pratt Institute*

Editor: Andrew Stasik
Editorial Consultant: Joan Ohrstrom
Design: Hermann Strohbach
Composition: David E. Seham Associates, Inc.
Printing: Braun-Brumfield, Inc.

EDITORIAL ADVISORY BOARD

Douglas Druick, Curator of Prints, The National Gallery of Canada
Alan Fern, Director, Research Department, Library of Congress
Sinclair H. Hitchings, Keeper of Prints, Boston Public Library
Colta Ives, Curator, Department of Prints and Photographs, The Metropolitan Museum of Art
Harold Joachim, Curator of Prints and Drawings, The Art Institute, Chicago
Robert Koch, Associate Chairman, Department of Art and Archeology, Princeton University
A. Hyatt Mayor, Curator Emeritus, Department of Prints and Photographs, The Metropolitan Museum of Art
Jo Miller, Gallery Director
Michael Ponce de Leon, Artist
Louise S. Richards, Curator, Department of Prints and Drawings, The Cleveland Museum of Art
Elke Morger Solomon, Curator and Artist
Walter L. Strauss, Author and Art Historian
Rudolf G. Wunderlich, President, Kennedy Galleries, Inc.

ADVISORY BOARD OF THE PRATT GRAPHICS CENTER

Walter Bareiss, Art Collector
Sylvan Cole, Jr., President, Associated American Artists Galleries
Fritz Eichenberg, Director Emeritus, Pratt Graphics Center
Franklin Feldman, Attorney
Judith Goldman, Writer and Editor
Ben Goldstein, Art Collector
Cleve Gray, Artist
James A. Houston, Associate Director of Design, Steuben Glass
Una E. Johnson, Curator and Author
Karl Kup, Curator and Author
James Laughlin, President, New Directions
William S. Lieberman, Chairman, Twentieth-Century Art Department, The Metropolitan Museum of Art
Gabor Peterdi, Artist
Eleanor Siebold, Director, Gallery of Graphic Arts

© Copyright 1980, Pratt Graphics Center, New York
160 Lexington Avenue, New York, N.Y. 10016
Printed in the United States of America.

Cover: Honoré Daumier, *Un Monsieur au Dessous*, 3 January 1841, lithograph (D. 718) (13¾ x 9¼ in.).
National Gallery of Art, Washington, D.C., Rosenwald Collection.

Contents

IN MEMORIAM JEAN CHARLOT

Charles Baudelaire	Tribute to Daumier	5
Peter Morse	Daumier's Early Lithographs	6
Jean Charlot	Daumier's Graphic Compositions	55
Donna Stein	Daumier: Photography and the Demand for Contemporaneity	97
Francine Tyler	The Impact of Daumier's Graphics on American Artists: c.1863–c.1923	109
Ben Goldstein	Daumier's Spirit in American Art	127

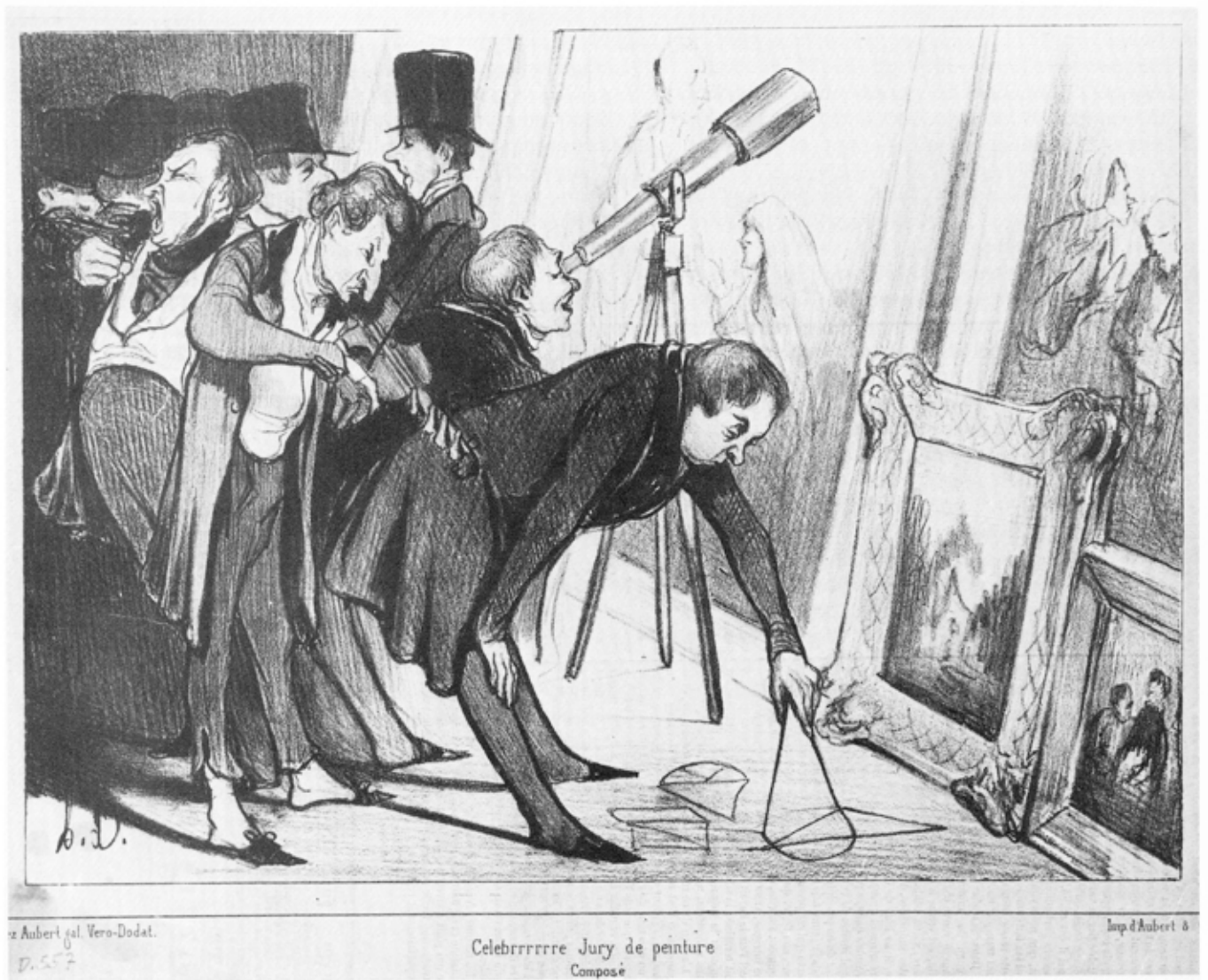

Fig. 1. Célébrrrrrre Jury de Peinture . . . (Delteil 557).

Jean Charlot

Daumier's Graphic Compositions



s had Rembrandt before him, Honoré Daumier at times graphically expressed his own ideas about those who have ideas about art. With Dutch bluntness, Rembrandt feigned agreement with contemporary critics who accused him of neglecting ideal beauty by sketching himself pants down, defecating over a canvas laid flat on the floor. Daumier, with French finesse, felt equally free to analyze what motley ideals, if any, moved the bigwigs who juried the official art event, the annual Salon. In a lithograph dating from the mid-nineteenth century (Fig.1), he describes the setting, a storage room where the pictures to be judged are propped haphazardly against the walls. Most jurors rudely turn their backs on the paintings, one yawns frantically. Obviously these vote nay. Three others, however, show a more open mind in that each assays the display against the touchstone of his personal ideal. One, dreaming of an art hitched high to a star, peers through a telescope angled toward infinity, thus missing the canvases heaped at his feet. A second, swayed by audiphone reveries, plays his violin to check if color and brushstrokes are in key with his melody. A third bends low. Armed with a carpenter's compass he traces in the dust of the storeroom floor segments of circles that intersect triangles and rectangles. The year is 1840. Is this man a prophet, envisioning things to come, cubism or geometric abstractions? Or is he old-fashioned enough to sigh for the polyhedral projections that engrossed a Luca Pacioli?

Célébrrrrrre Jury de Peinture, states the caption, as if to reassure us that these eccentric jurors are no more than puppets, created to raise a chuckle. Nevertheless, may one learn from

(Photographs kindly supplied by the author.)

this scene something of the aesthetic creed of Daumier the artist?

His crayon damns the jurors who turn their backs on what they are sworn to appraise. It softens its harshness as regards the well-meaning trio that at least is in earnest. High ideals (the astronomer), harmonious rhythms (the violinist), cool logic (the geometrician) are indeed ingredients found in Daumier's art. It was hitched to a star, a political one at its core, this Republic for which he pined and fought through the reigns of two kings and an emperor. As to music, his complex orchestration of chiaroscuros prompted Théophile Gautier to remark, "There is something of Michelangelo in that fellow." This paper, somehow, means to focus on a third and less publicized ingredient of Daumier's style: the devising of ordered compositions that the third juror, compass in hand, may for our purpose personify.

Geometry and story-telling

Fifteenth-century master painters, exacting craftsmen though they were, reached out for the realm of *cosa mentale*, that elusive entity that young Leonardo rated far above craft. Paolo Uccello wrestled a lifetime with perspective problems. First he would draft a linear rendering of a cube, check and recheck its geometrical accuracy, and only then add what accessories transformed it into a room, set as a stage for the display of some dramatic episode. In a panel of the famed Urbino predella, while the guilty one cowers behind a closed door, the soldiery wrathfully rams it into splinters. Is such a display of force truly necessary to demolish a feat of projective geometry?

Contrariwise, Daumier's images of a three-



Fig. 2. *Madame déménage!* (Delteil 3590).

dimensional world started from direct observation. He did not handle compass and ruler but neither did he draw from the model before attacking the lithographic stone. He puzzled at the doings of his artist friends, Charles-François Daubigny among them. Like hunters they left home at daybreak in quest of a motif, shod with high boots, a heavy back pack, holding an alpenstock *en lieu* of a gun. The quarry sought was a landscape worthy of their brush, Barbizon oaks preferred. Daumier's hunting grounds spanned the whole city, including unusual haunts that Emile Zola would later rediscover and describe in *Le Ventre de Paris*. Daumier befriended all workers, market strong men, stevedores, butchers, and bakers, but on his strolls would leave at home, if ever he owned one, his sketchbook. His true subject was life's flow and he did not care to freeze, even for a moment, its vital rhythms.

He also treasured museum memories, Alexandre Lenoir's Musée des Monuments Français and visits to the Louvre, lingering in sculpture halls. Over Greek marbles smooth as soap he rated Roman bronze bas-reliefs molded by anonymous jobbers, Caesars, horses, legion-

naires, barbarians, the victors and the dead, bunched as grapes on a stem. Daumier kept at home a cast from Trajan's column. Haphazard though it was, this classical training made him aware of the basic grandeur of geometric solids. Cylinders, pyramids, spheres buttress some of his graphics, translated, as may be inferred, into his peculiar city slang.

Cylinders can be news. *Madame déménage* (Fig. 2), a nightmarish Death astride the boiler of her locomotive, speeds ahead full steam. More prosaically, *Société catholique du Baptême organisée pour le salut des buveurs parisiens . . .* (Fig. 3), workers unloading casks of wine, rolling and piling them on the quays of Bercy, the barrels not unlike fragmented columns, their flaring profiles aping the Greek module. This straightforward rendering contrasts with a bizarre follow-up, *C'est un peu dur d'être obligé . . .* (Fig. 4). In mid-century, many Parisians were rendered homeless by the razing of whole quarters of the city, brought about by Baron Haussmann's inflexible will to make place for the Grands Boulevards. Putting the casks seen on the quays of Bercy to surrealistic uses, Daumier depicts folks who attempt to live in barrels, deploring the fact they are no Diogenes.

M. Prud'homme se passant la fantaisie . . . (Fig. 5) adapts the cone, or rather here the pyramid, to the headlines of the day. *Turcos*, fez-coiffed, dark-skinned Algerian troops on their way to the Crimea, encamped on the Champs de Mars, an exotic sight that drew Parisian idlers.

The sphere is recurrently newsworthy. Balloons make news. *Nadar élevant le Photographie à la hauteur de l'Art* (D. 3248; see Stein, Fig. 15) hails the birth of aerial photography. *L'Équilibre européen* (Fig. 6) features another kind of sphere, our planet, precariously balanced on the points of bayonets. In 1856, fashions changed radically. Crinolines, ballooning over metal hoops, filled promenades with their domical silky shapes. *Nouvelles modes du demi-monde . . .* (Fig. 7), drawing a parallel with the hoop-petticoats of the preceding century, is fairly realistic reporting. Published less than a week later, *Manière d'utiliser les jupons . . .* (Fig. 8) creates a phantasmagory wherein pretty messengers of the new fashion parachute to earth from some empyrean heights!

One rectangular solid, basic to Daumier's compositions, was not entirely of his free choice. Its six facets echoed in depth the rectangle that the format of the illustrated weeklies imposed. We shall refer to it loosely as a cube. On this one motif Daumier played endless variations, but, before analyzing this limited pictorial space in which his personages most often move and breathe, let us attempt to define his personal conception of the picture plane.

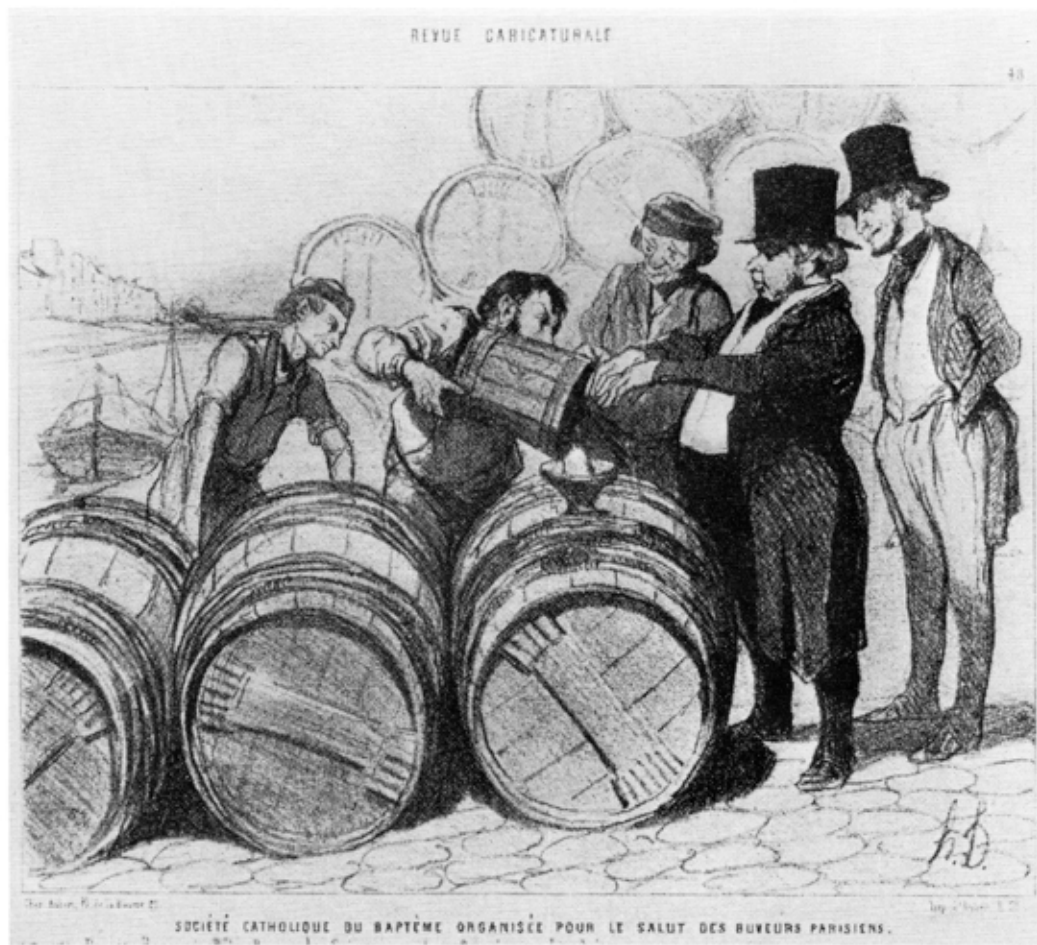

Fig. 3. Société catholique du Baptême organisée pour le salut des buveurs parisiens . . . (Delteil 1016).

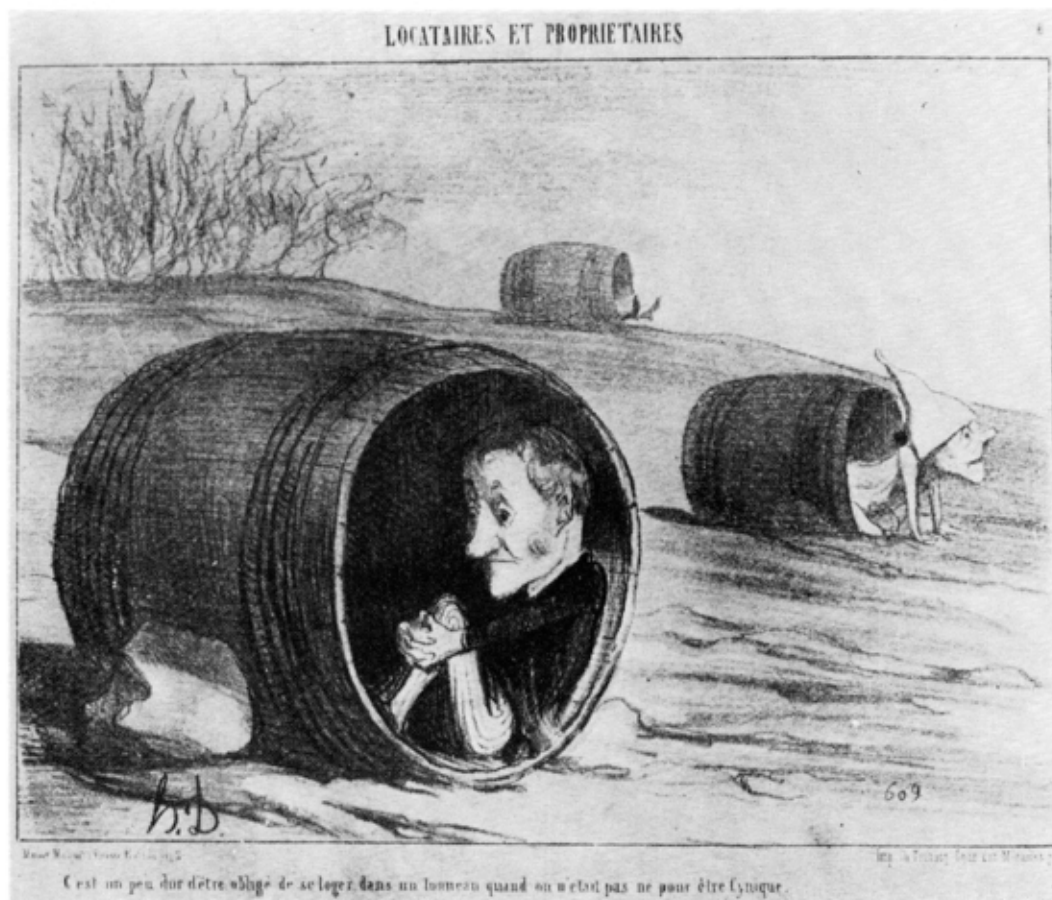

Fig. 4. C'est un peu dur d'être obligé de se loger dans un tonneau . . . (Delteil 2575).

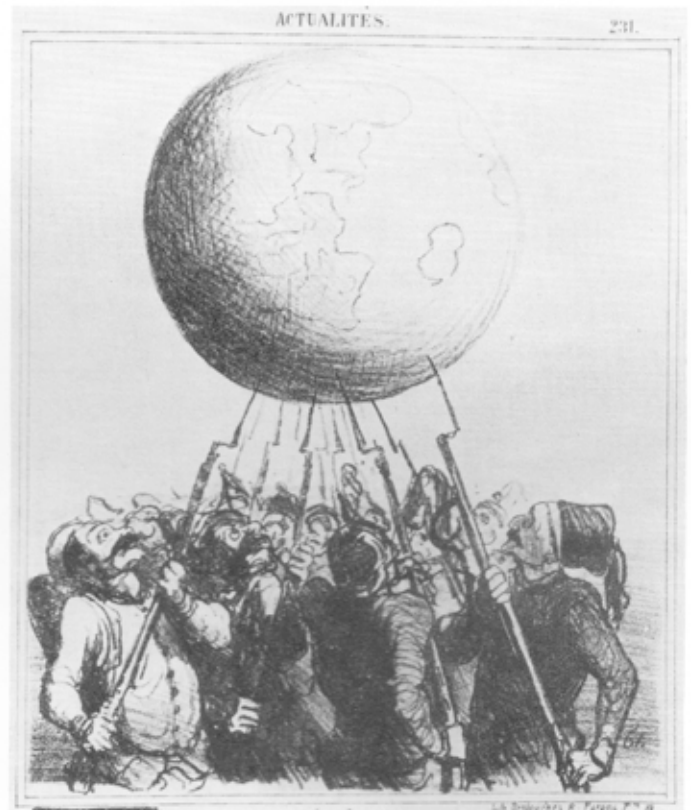
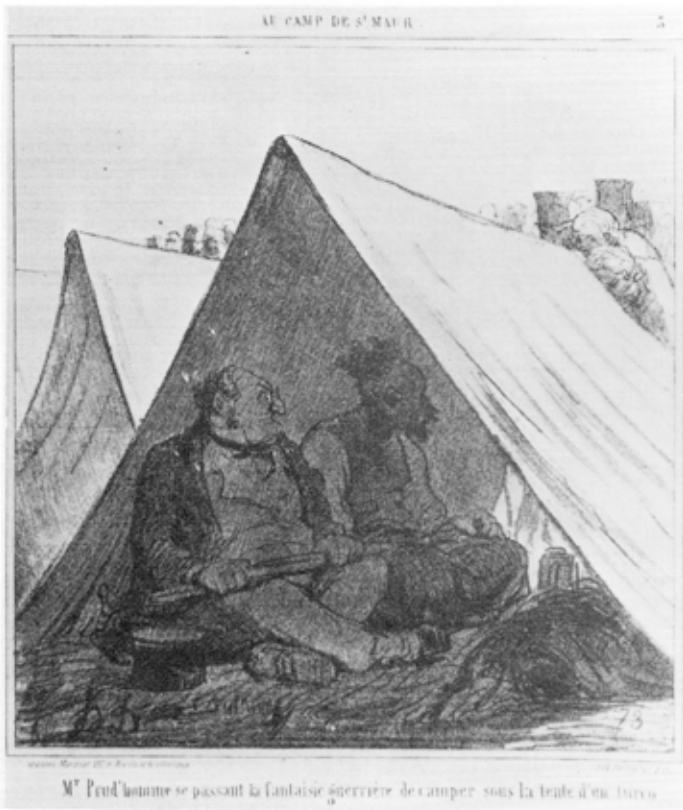

Fig. 5. M. Prud'homme se passant la fantaisie . . . (Delteil 3194). Fig. 6. L'Equilibre européen (Delteil 3540).



Artisanal concept of the picture plane

Daumier was not a bookish man, and little inclined to ponder Euclidean absolutes. It was rather his heightened visual experience that taught him wordlessly how to build a geometric underpinning for his compositions. It is therefore pertinent to survey the milieu in which his lithographs were created.

Among his working companions at the publisher's shop, he identified readily with the manual worker, the printer, an apron at his waist, cockily coiffed with the badge of his trade, a paper cap of folded proof sheets. Daumier lovingly depicts him at work, manning the handle of a Stanhope press (D-71), or boldly defying kings, sleeves rolled up, ready at a dare to erect street barricades (D-133). Daumier felt less at ease with another group of equally dedicated coworkers, the white-collar wits whose tool was the pen. He rarely bothered with the word for word of his captions, and came to feel a strong dislike for the famed set of *One Hundred and One Robert Macaires*, because of its overflowing and involuted dialogues, created with special care and pride by Charles Philipon.

Daumier nursed no illusion as to the fate of his weekly cartoons, barred from the haughty seclusion of connoisseurs' portfolios. For the subscriber to *Le Caricature* or *Le Charivari*, his cartoons were little more than vignettes, a visual rest between text pages, to be flipped out of sight at will. The reader thought of them as drawn on paper but Daumier knew better. Four thousand times throughout his lifetime he sat or stood facing a block of stone quarried out of the Bavarian site whence came the stones that drove Aloys Senefelder to invent lithography.

As a practicing lithographer, I can testify that to handle stones, grain stones, and draw on them makes one familiar with each, its weight, its color, hardness, and idiosyncracies. This means more than an artisanal detail, and throws a sidelight on the oft-quoted pairing of Daumier with Michelangelo. The Italian loved stones for themselves, collecting choice Carrara blocks that he piled on papal plazas. As to Daumier, he lived his working hours among stones. At the start of each day's chore, propping one up, he faced a small architecture, a rectangular solid. Even though his task was to maculate its surface with crayon, Daumier could hardly escape the stone's solid assertion of self.

The image of the propped-up lithographic stone, mirrored day after working day on his retina, was fated to surface in his work, slightly camouflaged to play its part in a story. *Le Peuple Souverain* (Fig. 9), despite a hardly convincing superstructure and a hand-lettered assertion that this monolith is a ballot box, is stone; its



Fig. 8. *Manière d'utiliser les jupons nouvellement mis à la mode* (Delteil 2759).

shape, its thickness, its hardness, that of the lithographic stone.

Tu resteras dehors . . . (Fig. 10), the rotting imperial eagle crucified onto the Book of History; does it deal as stated with a book, symbolic though it be, or, unacknowledged even by Daumier, is it not rather a transmogrified image of the very stone he was facing when he drew this masterpiece?

Theoreticians, as they refer to the picture plane, conceive of it as an insubstantial entity. In a woodcut illustrating his *Treatise of Measurements*, published in 1525, Albrecht Dürer depicts a Rube Goldberg sort of machine. A hook with a string attached acts as a mechanical eye gathering to itself a cone of optical lines. An assistant, keeping the string taut, contacts with it a series of points on the surface of the model, in this example a lute. Somewhere on its course between hook and lute, the string passes within an empty frame. For each motion the master of the shop—artist, mathematician, or both—measures the distance from the string to the inner edges of the frame. Point after point is thus accurately reported on a gessoed panel and



Fig. 9. *Le Peuple Souverain* (Delteil 3928).

a line threaded through the points. The result is a mechanical draft of the model, a linear photograph. Thus understood, the picture plane is literally a nothingness, a thin slice of air that only the solid frame marks as distinct from the air we breathe.

Artisanal common sense taught Daumier an opposite truth. As stated, his picture plane is stone, indeed hard to mistake for air. *Bas-relief en pain d' épices . . .* (Fig. 11) quizzically illustrates the fact, transmuting stone into gingerbread, but it yet retains the grayness and the grain of the prepared surface, and borrows the stone's beveled edge, distinct from the ruled lines that routinely frame most of Daumier's published cartoons.

One of the last lithographs that Daumier ever drew features even more emphatically the solidity of the picture plane. *Ce que d'aucuns appellent un progrès* (Fig. 12) erects a vertical wall of planking that represents a pillory. For the moment untenanted, its left half exhibits holes for the head, hands, and feet of a culprit. Tenanted, the right half imprisons the Press, a woman coiffed with the telltale cap of folded news sheet, a pen in hand. Her head, hands, and feet protrude through the holes. So integrated with the picture plane are the planks of the pillory that head, hands, and feet visually jut forward, ahead of the page.

Progressive approach to depth

Lithography as his major graphic medium was not for Daumier a free choice. Through most of his lifetime it remained the cheapest and speediest way of multiplying an image and thus, for his budget-minded publishers, a must. That the craft induced in Daumier specific attitudes does not imply that his wish was to revolutionize or renovate. As skillfully as the best among his contemporaries, he knew how to conjure volume, space, depth, motion. Something, however, remains of his lithographer's scruples that stamp his solutions as distinctive. Even where depth is explicitly involved he reserves part of the image area to act as *repoussoir*, an opaque plane often left bare. Parallel to the picture plane, it is a vestigial reminder of the solid stone surface.

T'as tort de vouloir afficher cette grande annonce . . . (Fig. 13) is an extreme example in that this opaque plane, in this case a street wall,



Fig. 10. *Tu resteras dehors et cloué sur la porte! . . .* (Delteil 3853).

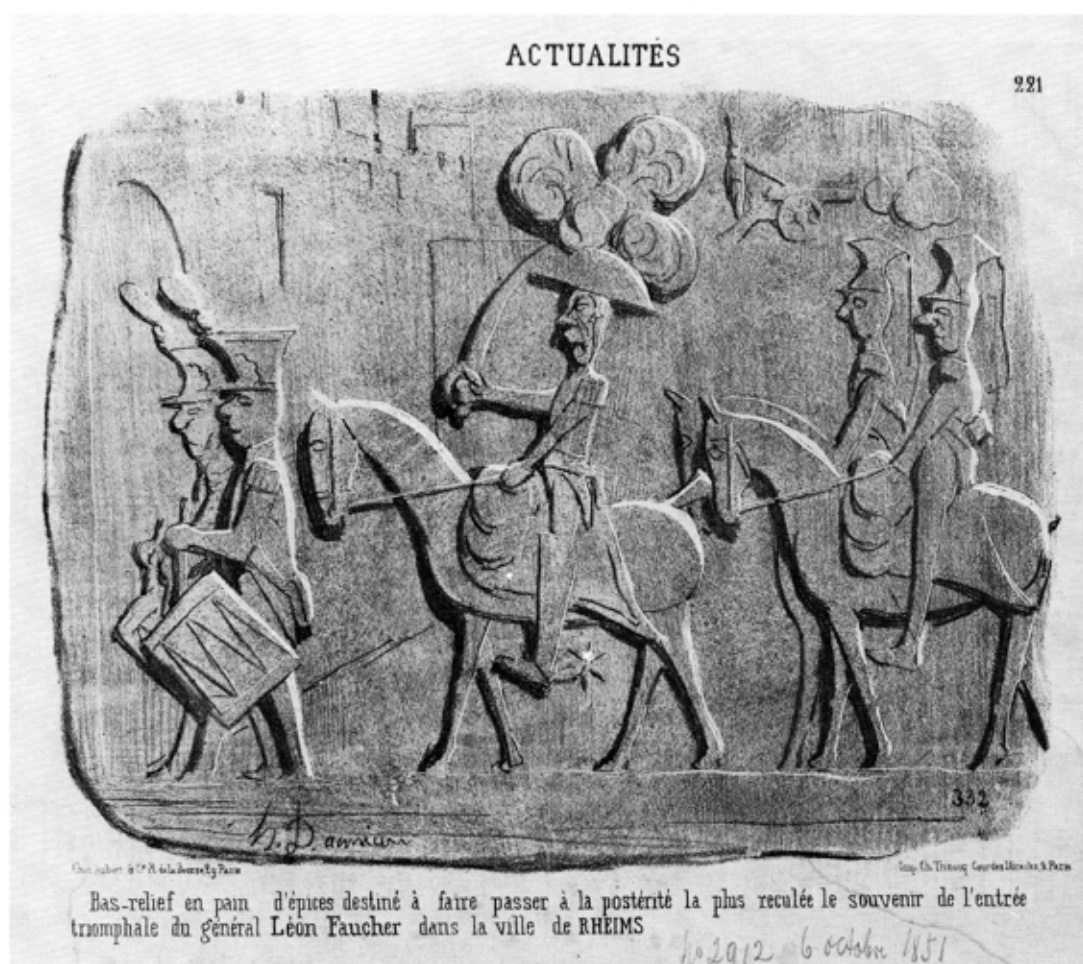

Fig. 11. Bas-relief en pain d'épices destiné à faire passer . . . (Delteil 2155).

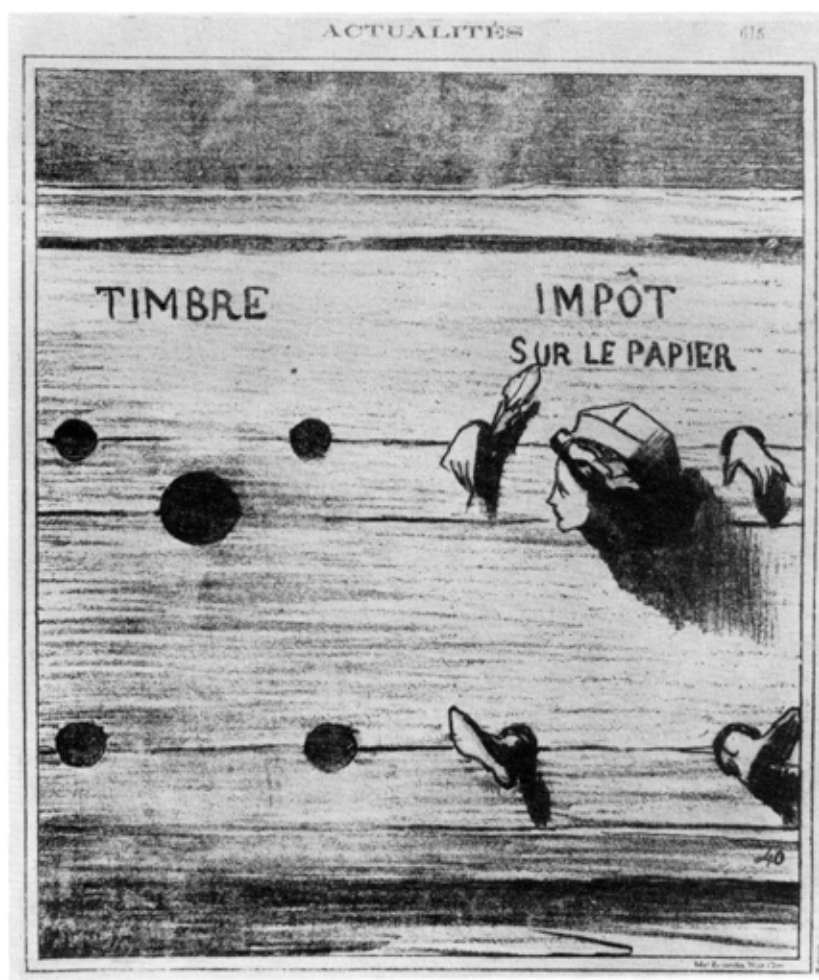

Fig. 12. Ce que d'aucuns appellent un progrès (Delteil 3879).

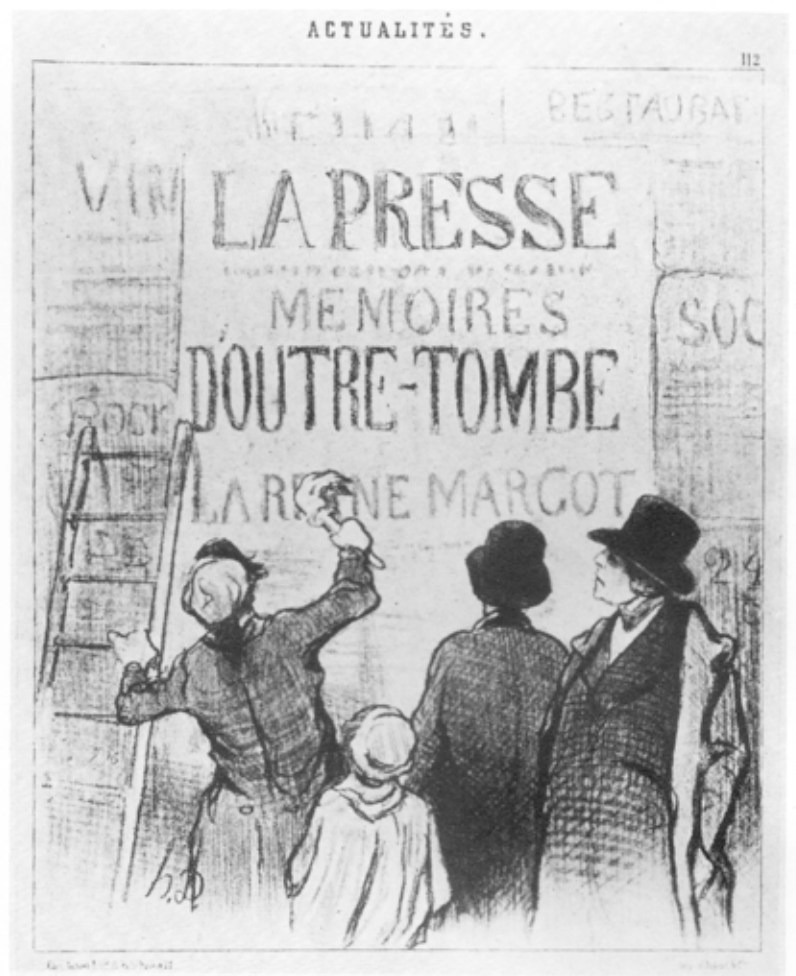

Fig. 13. T'as tort de vouloir afficher cette grande annonce dans de mois-ci . . . (Delteil 1270).

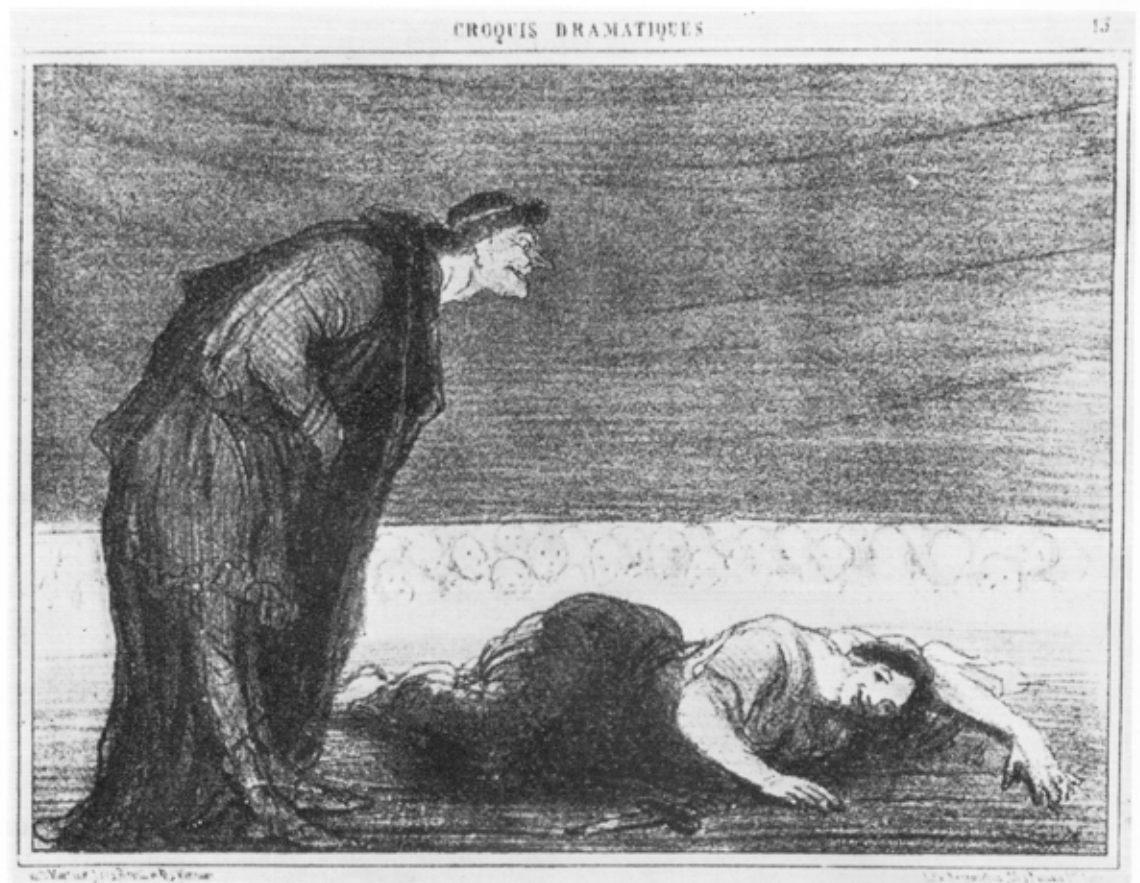

Fig. 14. La Princesse—Voyons, être féroce, finis-en donc vite . . . (Delteil 2909).

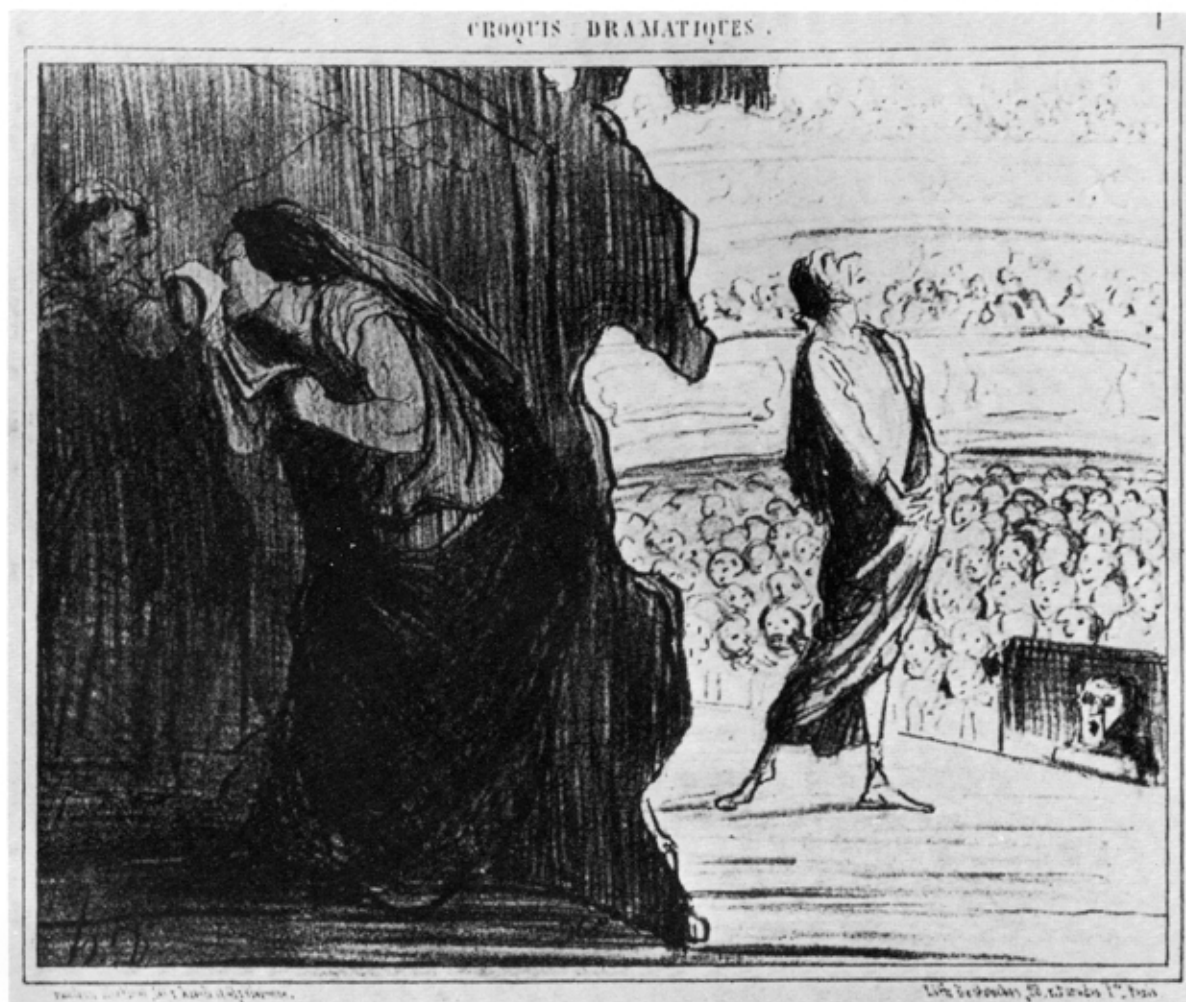

Fig. 15. *Une Reine se préparant à une grande tirade* (Delteil 2897).

spreads over the total area of the picture. The diagonal device of a raised ladder casting its shadow on the wall alerts the eye to the fact that between it and us lies a pocket of space. The wall is realistically plastered with posters, or rather broadsides—the pictorial poster being not yet current. Recent advertisements overlap dilapidated ones. The newest is just now being slapped plumb over the papered wall by a bill sticker, his square brush dripping paste. It proclaims how Chateaubriand's *Memoirs* start in serial form in a daily, *La Presse*. A few passers-by stop and stare. Strictly parallel to the picture plane, the wall recedes in space ever so slightly, opening a corridor of space wide enough for Daumier's personages to move and breathe in.

In the next example, this opaque area opens thriftily to reveal a horizontal glimpse of deep space. *La Princesse—Voyons, être féroce, finis-en . . .* (Fig. 14) deals with the world of the theater. It locates the viewer upstage while a classical tragedy comes to its close. The togaed Roman has uttered the last syllables of a lengthy tirade. The heroine lies at his feet, presumably stabbed

to death. The stage lights have just been darkened, the curtain comes down. To "snap" the scene, Daumier chose the split second before it reaches the floor in its fall. Through the narrow strip still left gaping, we get a panoramic glimpse of the auditorium where lights are already blazing. Still seated, stunned by the traumatic ending, the audience will next burst into applause. The curtain, plainly rectangular, stops the eye as efficiently as did the street wall.

Une Reine se préparant à une grande tirade (Fig. 15) distributes equably the two opposites, open space and space walled out of sight. Viewed from the wings, the classical drama is caught in mid-course. The right half of the lithograph pictures the lighted part of the stage, a Roman orator strutting and orating, the spectators tiered vertically from pit to ceiling drinking in his eloquence.

Bathed in darkness, the left half hides from view the Queen. Prudently, she blows her nose to the full before crossing into public view and in her turn declaim! Here Daumier divides light from darkness, shallow space from deep

Fig. 18. *Bouderie conjugale* (Delteil 1561).

space, by the ragged edge of a stage flat. It stands in total contrast to the preceding device, a stage curtain as plain as a Euclidean figure.

When this device of an opaque area is omitted, Daumier nevertheless guides the eye back to the picture plane. *Des Parisiens dans l'attente du plaisir* (Fig. 16) shows patient citizens queuing outside a theater, expressively displaying frustration, hope, boredom, impatience, resignation. They are visually caged inside a stark combination of verticals and horizontals as impressively detached from human passions as an abstract by Piet Mondrian.

Even in scenes that deal with infinity, Daumier manages some linear device that ties in with the surface of the page. *Nouvelle suspension aérienne* (Fig. 17) represents Dame Europe lying magically relaxed on thin air, her elbow resting comfortably on the point of a bayonet. The right angle thus achieved is a forceful reminder of the rectangular format.

Exceptions strengthen the rule. *Bouderie conjugale* (Fig. 18) is one of the few compositions based in toto on unlimited space. To compare it with the previous examples should clarify the point.

Punch and Judy geometry

The Paris of Napoleon III, despite the boulevards abuilding, was, or so it seems in retrospect, still rustic. A relaxed walk through the Champs-Élysées bathed the Parisian in nature's lushness. On low benches lined under the chestnut trees moppets sat with their nurses, on occasion joined by Daumier himself. All watched delighted a Guignol play, the French Punch and Judy show. The theater itself was a portable affair, hardly more than a box, high enough and deep enough to hide from view the puppeteer and to store his stock of actors, sets, and accessories, the major one a bludgeon used for bastinadoes. *Marionnettes politiques* (Fig. 19), Monsieur Adolphe Thiers manipulating subservient congressmen, helps us visualize the layout from inside the puppeteer's stall.

What the audience saw was sheer magic. *Les principaux personnages de la Comédie . . .* (Fig. 20) presents a spectator's view of the stage, its uprights upholding a curved pediment, folksy version of a rococo gone to seed. Seen in full light against the shady depth, three marionettes, the royalist, the Bonapartist, and a cleric,

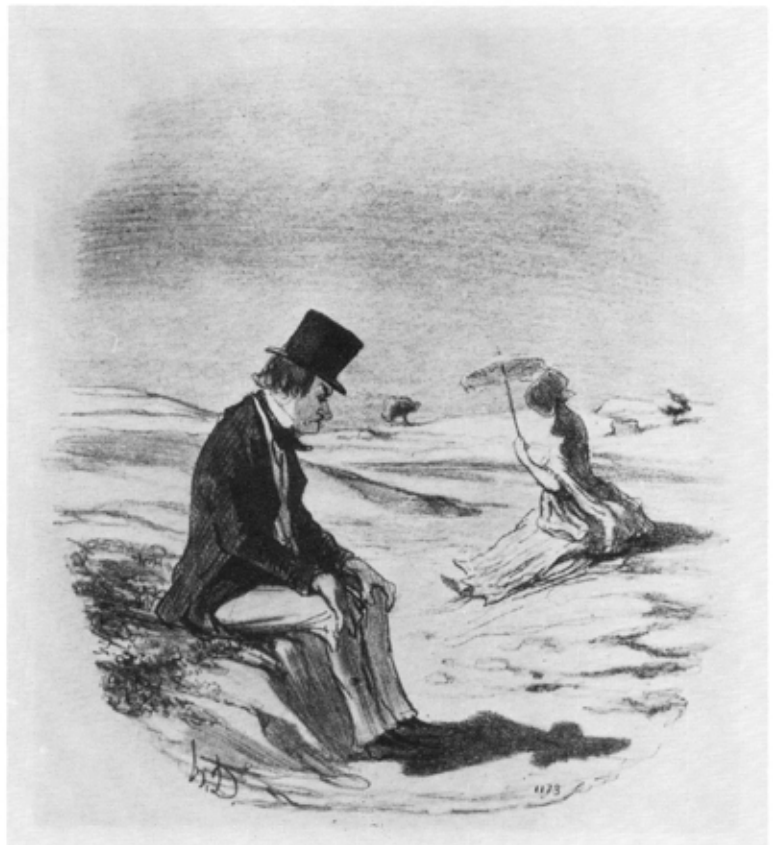

Fig. 19. *Marionnettes politiques* (Delteil 2003).



Fig. 20. *Les principaux personnages de la Comédie . . .* (Delteil 2156).



Fig. 21. *Le nouveau Polichinelle Napolitain* (Delteil 2636).

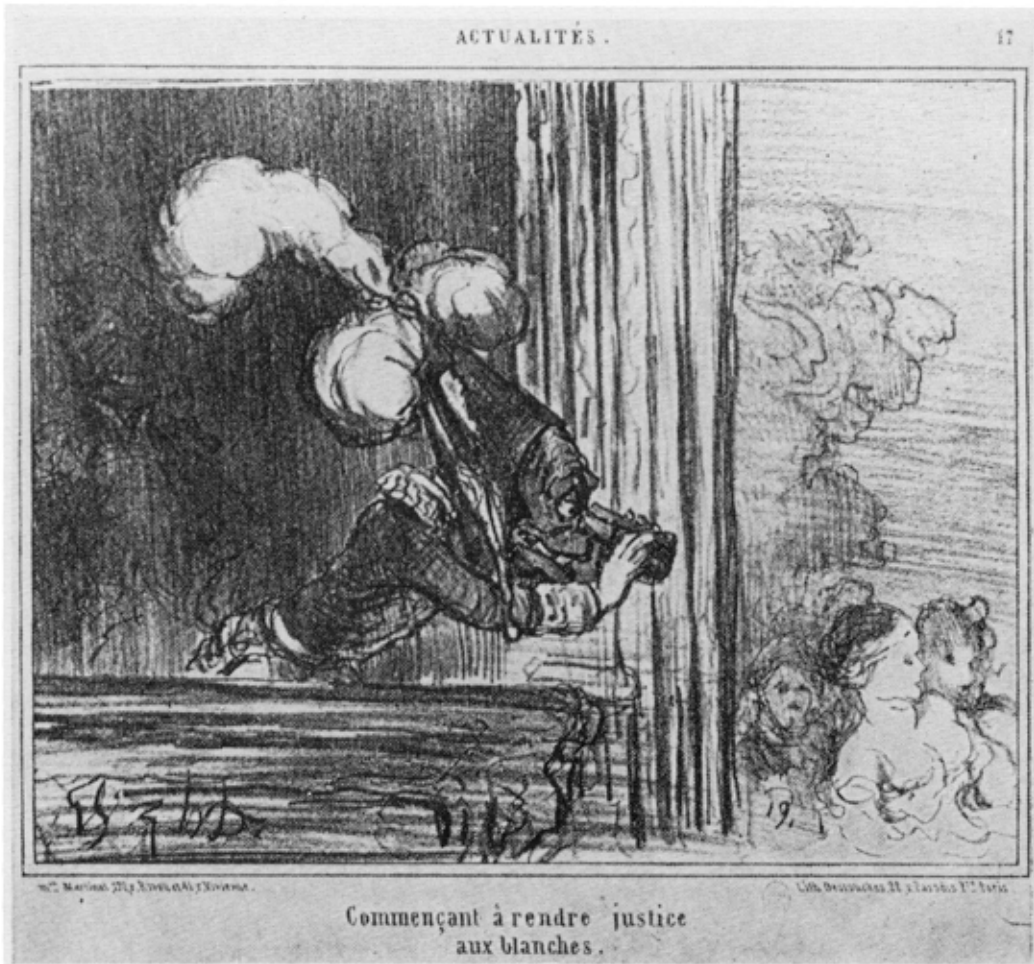

Fig. 22 *Commencant à rendre justice aux blanches* (Delteil 3151).

do their thing. Enough is represented of the facade of the theater to identify it with the picture plane.

Le nouveau Polichinelle Napolitain (Fig. 21), identically composed, counterbalances the depth of the stage by a bold device previously met in dramatic context in *Ce que d'aucuns appellent un progrès* (Fig. 12). Here a heap of mock corpses, bastionadoed to death, overhang, heads bashed and arms limp, casting realistic shadows over the planks of the facade, thus occupying a space set ahead of the picture plane.

Daumier may well have failed to draw a strict demarcation between the behavior of puppets and that of humans. *Commencant à rendre justice aux blanches* (Fig. 22) marks a transition. The setting is that of a Guignol play, modified from a frontal to a three-quarter view to allow for a bit of landscape, a park where beautiful females promenade. Faustin Elie Soulouque, the exiled emperor of Haiti, ogles them from high. His house looks suspiciously like a Guignol box; the window he leans through could be his stage. The texture of the face of the august exile, a black, is treated as whittled wood rather than



Fig. 23. *Ménage modèle—depuis trente ans, ils cultivent la vertu . . .* (Delteil 1482).



Fig. 24. Venant de donner
le dernier coup de Pinceau
. . . (Delteil 2663).



human flesh. Soulouque holds his telescope like a bludgeon, the favorite prop of Polichinelle.

Ménage modèle . . . (Fig. 23) returns to the orthodox frontal view. Fully human, a husband and wife dawdle contentedly at their window, basking in the sunlight. Behind them one glimpses a shady interior. Though camouflaged with flower pots and vines, the essentials of the Guignol scheme are hardly modified.

That Daumier's approach to descriptive geometry was thus apparently casual, amused even, may prove deceptive. He confronts its problems with a oneness of purpose equal to that of fifteenth-century geometers, men little inclined to watch Punch and Judy shows.

Story-telling as a means of composition

It would be misleading to present Daumier's geometrical leanings as a thought-out logical progression. Rather they parallel the happenings of a séance, wherein the ghostly visitor, often dimly perceived, materializes to the full on rare occasions.

Fig. 25. *Effet de lunes* (Delteil 648).

A key to Daumier's optical alphabet remains the rectangle, which in turn begets the cube. It was no brain child, however, but a rectangle his own eyes did see. While he worked, it was the surface of a stone maculate with crayon. Published, it translated into a sheet of paper smeared with ink. Between what his eye saw and what his hand drew, these sights suffered sea changes. Rectangles invade sundry themes, most obviously those related to painters and their paintings. The stretcher bars' mitred square, the sculptured and gaudily gilded frames inspired Daumier more often than the brushwork, portraits, still lifes, or landscapes.

The tales he tells have simple plots. Pridefully the artist brings his pictures to the official Salon (D. 2664). Mournfully he returns home, his rejected masterpieces laid on a stretcher (D. 2665). The Salon opens, disclosing pictures hung row upon row as sardines laid in a can (D. 3294). The famous art critic whisks through, notebook in hand, painters curtsying in his path (D. 3448). Thus the themes told in human terms. Optically, a single title fits them all, "In Praise of the Rectangle."

Venant de donner le dernier coup de pinceau . . . (Fig. 24) illustrates the point. Having brushed in his last stroke and elated at the result, the painter improvises a self-congratulatory jig. The ill-kept studio is a visual encyclopedia of rectangles, of all sizes and seen in all perspectives, versos and rectos, plumb and off-plumb, vying with the dancer in angularities.

Weary of perspective lines that smack of the blackboard, Daumier treads cautiously into regulated depth. Suggestions, rather than descriptions, abound. *Effet de lunes* (Fig. 25) features a window, a French window, of course, both its casements open at an angle. Hinged together, the three rectangular planes create a recess that accommodates a couple gazing at the moon. True, the stark trio of rectangles opens on a vista of the night sky. Disregard the view, or rather minimize it as one would a painted backdrop, a favorite accessory of nineteenth-century portrait photographers. Concentrate instead on the orderly presentation of measured space in the foreground, though it is, as Daumier wished it, willfully understated.

A Clichy . . . (Fig. 26) uses an identical setting to express a more astringent mood. Two inmates of a jail for debtors face an open window. The serried verticals of its prison bars force their eyes and ours back to the foreground with its Spartan spatial scheme.

Un Français peint par lui-même (Fig. 27) is more tightly articulated. Canvas and easel are



Fig. 26. *A Clichy*.—*Dire que dans quelques semaines . . .* (Delteil 3423).



Fig. 27. *Un Français peint par lui-même* (Delteil 1722).



Fig. 28. *Voilà une bonne hauteur pour mettre mon baromètre . . .* (Delteil 1622).

parallel to the picture plane. Set at a right angle to it, the mirror activates perspective lines that guide the eye from surface to depth. The corner of the studio is an enlarged echo of the angular setup seen in the foreground.

Both cubist and abstractionist delved in our century into the relation of planes. Despising the anecdotal, both deemed story-telling an unforgivable faux pas. For Daumier, naive if you wish, the plot, the visual pun even, were never shunned but sought. Granted that his livelihood depended on it, nevertheless it was no concession on his part. Memories of the museum taught him how to interlace body lan-

guage with abstract geometry. One follows the index finger of John the Baptist to its goal, Christ. Was Titian unaware of the casually self-centered gesture of his reclining Venuses? Here Daumier's painter, engrossed in his work—if not Gustave Courbet himself, one of his followers—performs a more complex task than painting. Both his hands and his ego are tied to the job, but his head and eyes, pivoting from mirror to canvas and from canvas to mirror, involve the viewer in their alternate scanning. Were it not for this device, both psychological and mechanical, the dynamics of the scene would come to a stop.

The cube

It is easier to express depth than lack of depth. The human eye, highly trained by everyday experience, sees depth even when the painter did not so wish. A rectangle within a rectangle—any one of Josef Albers' *In Praise of the Square*—may be interpreted in depth (Drwg. A). To will depth, to emphasize depth, add webs of lines converging toward infinity, cut short at their junction by the inner rectangle (Drwg. B). Translating them as beams on a ceiling and pavement on a floor, Uccello, in one of the panels of the Urbino predella, has left us a cool masterpiece, wherein linear purity outweighs human drama (Drwg. C).

To describe a cubic space, Daumier favors this frontal view. Its surface echoes the format of the page. Read in three dimensions, Parisians, who live inside cubes, enrich the familiar sight with their own memories. *Voilà une bonne hauteur pour mettre mon baromètre . . .* (Fig. 28) features a cubic space, set for the nonce in linear perspective. To add zest to this geometric draft, Daumier adds a pinch of psychology. Could we doubt the cube is meant as a room when we watch the caged couple measuring its width and its height? The husband promenades a tape measure against its walls. His spouse checks the verticals by tapping the tip of her umbrella against the ceiling.

In *Il faut me trouver là-dedans trois pièces . . .* (Fig. 29), Daumier, with a few swift strokes, sets in orthodox perspective the naked inside of

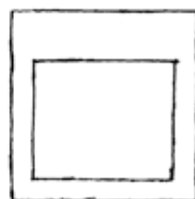

A

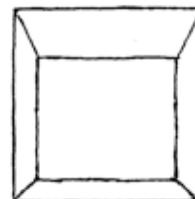

B



C

Uccello

LOCATAIRES ET PROPRIÉTAIRES.

5

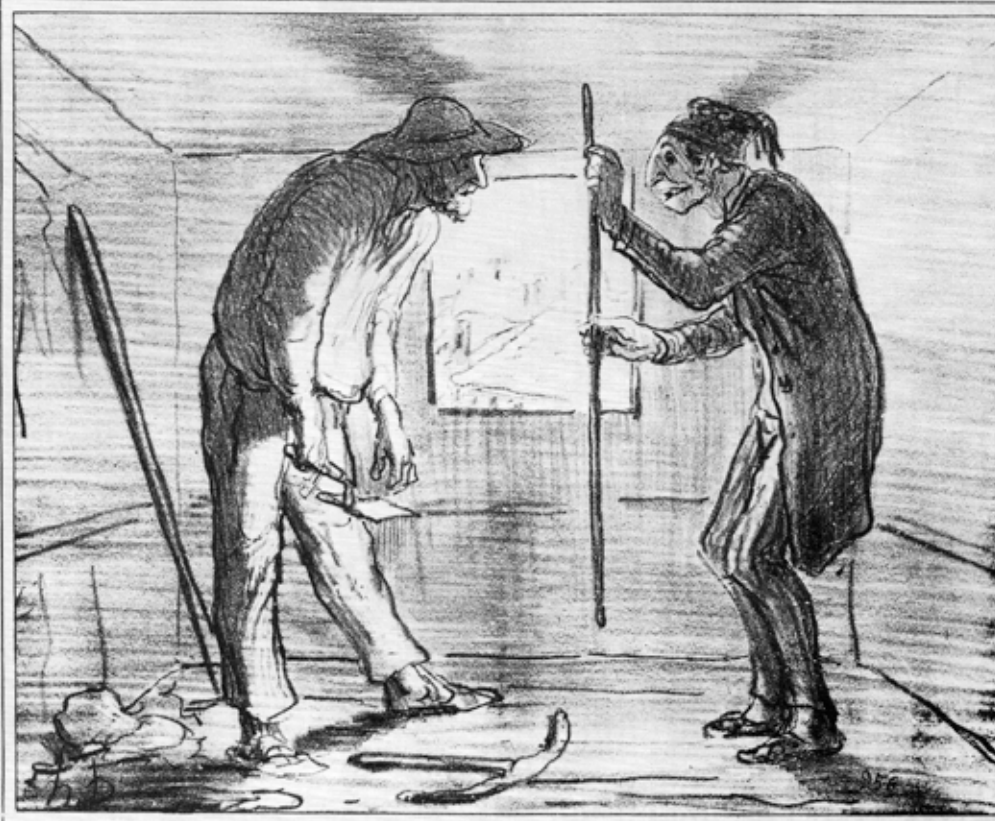

— Il faut me trouver là dedans trois pièces et une cuisine !..

Fig. 29. Il faut me trouver là-dedans trois pièces . . . (Delteil 2838).

PHYSIONOMIES DES CHEMINS DE FER

5



Fig. 30. Train de plaisir de Paris à S^t-Germain:— Wagon de deuxième classe (Delteil 2283).

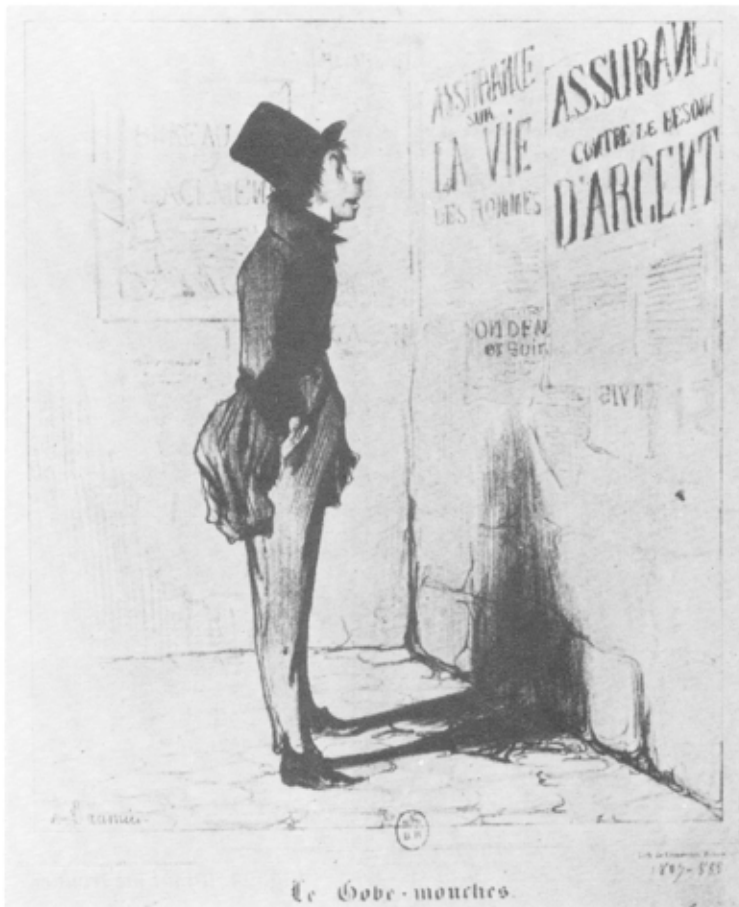

Fig. 31. *Le Gobe-mouches*. *L'origine de cet animal se perd . . .* (Delteil 527).

a cube. A single window transforms it into a room. A greedy landlord, bent on remodeling this vacuum into a rentable apartment, confers with his mason. To illustrate the landlord's stinginess, Daumier lowers the ceiling until the heads of both personages butt hard against it. A visual joke, granted, but also a serious means of emphasizing cubic depth. Added to the shadows cast on the floor, those diagonally cast on the ceiling intensify with their chiaroscuro the reality of the cubic space at which the linear draft merely hinted.

In mid-century, to cubic rooms were added, thanks to a newfangled invention, the railway, cubes on wheels. Daumier sharpened his wit watching a handful of people, strangers to each other, crowd like cattle in this novel kind of box. *Train de plaisir de Paris à St Germain . . .* (Fig. 30) traps the travelers in the perspective web of a passenger car, the austere grayness of the bare interior contrasting with the lighted outer space and the lightning speed of the rushing landscape glimpsed through the window.

Psychology as a visual means

Besides using as a working cog in his compositions patterns of human behavior, Daumier handles another means equally out of bounds for the geometrician, chiaroscuro. Courbet, a contemporary, used it to make explicit the solidity of forms. Daumier favors it for another reason, as a worthwhile detour to bypass linear perspective. To differentiate shallow space from deep space he emphasizes contrasts between areas of light and dark far beyond any realistic purpose. In *Il faut me trouver là-dedans trois pièces* (Fig. 29) we saw how a room barely suggested by a few scribbled lines acquired substantial credibility once chiaroscuro came into play.

Le Gobe-mouches . . . (Fig. 31) illustrates that same point with primer-book clarity. The adolescent scanning street ads—could it be young Daumier at his first job, carrying documents from lawyers' desks to courtrooms?—would be planted in a near vacuum, were it not for the resolutely dominant cast shadow crawling on the pavement to break at a right angle as it climbs up the vertical wall, thus defining the locus of the scene.

When pressed for time, Daumier seldom hesitated to involve the viewer by presenting him



Fig. 32. *Ah bah! . . . Le locataire du premier, qui prend la taille de mon épouse! . . .* (Delteil 704).

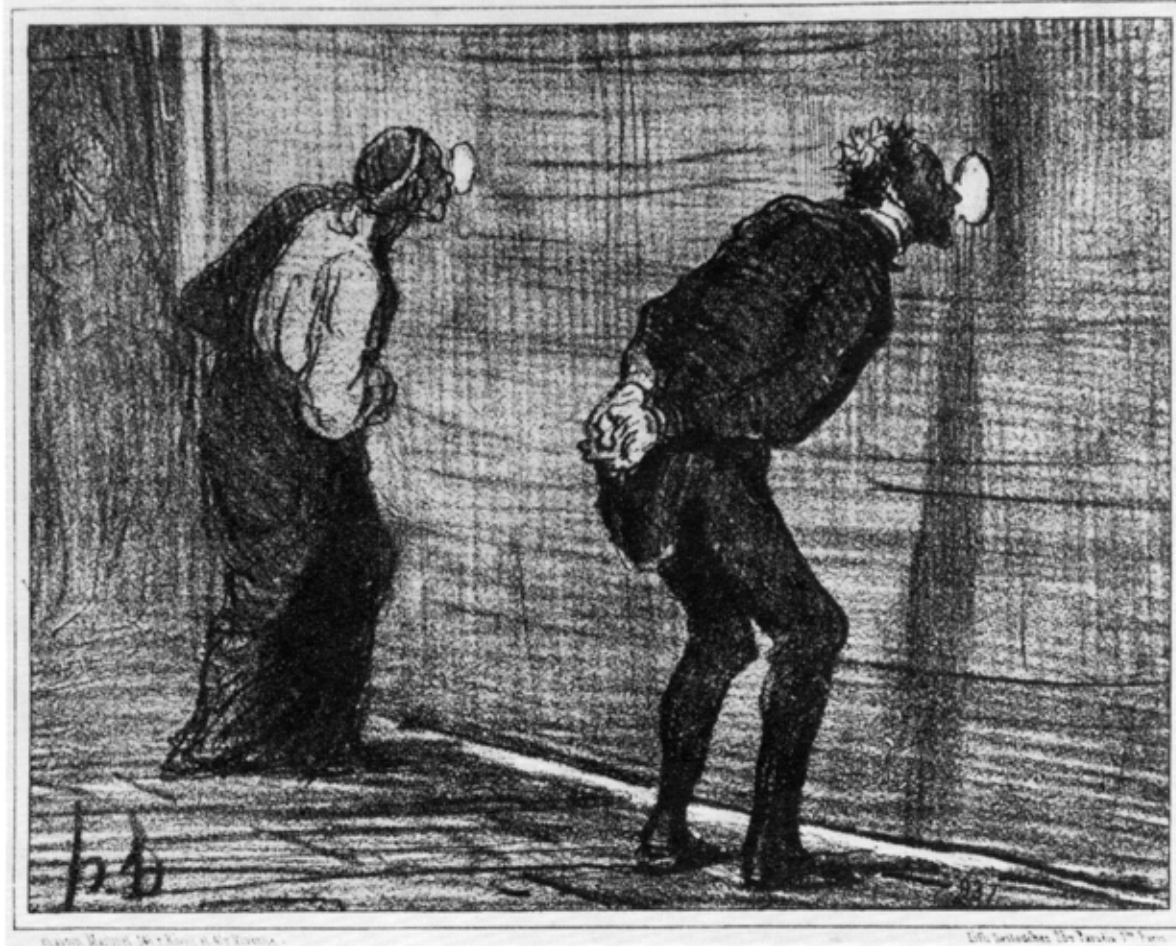

Fig. 33. *L'Acteur . . . On voit bien qu'il fait chaud . . . trois spectateurs . . .* (Delteil 2826).

with a scent to follow. He banked on the fact that nineteenth-century Parisians were born, lived, and died in rooms, apartment buildings being to them what the hive is to the bee. The concierge, a more tyrannical figure than today's janitor, ruled the human hive. From his *loge*, a cubicle poised at the crossroads of all comings and goings, he missed little. What he did miss was more than made up by what he inferred while dusting stairs and corridors. Keyholes were his watchtowers.

Ah bah! . . . Le locataire du premier . . . (Fig. 32) is staged on the landing between a stairhead and an apartment door. A keyhole, technically a crayon dot, is the simple device that, besides implying unseen vistas, reaffirms the opacity, hence the reality, of the skimpily sketched architecture. As the concierge locks his eye to the keyhole so do we.

Gifted with a trained imagination, Daumier confidently leaves much, indeed at times most, to the viewer's imagination. His pictorial shorthand need not be commensurate with the complexity of an episode. *L'Acteur . . . On voit bien qu'il fait chaud . . .* (Fig. 33) brings us back to

the theatrical world as seen from the wings. The curtain is down, the stage in darkness, the auditorium lit, the play not yet begun. Technically, Daumier covered the surface of the lithographic stone with a crayon halftone on which is sketched, black on gray, a pair of indistinct silhouettes, the director and an actress. Two white dots are scraped out of the halftone, peepholes through which the disheartened couple surveys a deserted auditorium.

Keyholes, peepholes, add interest to the vertical planes that limit the ever recurrent cubic space. At other times, Daumier wills us to focus on one of the horizontal planes, up or down, ceiling or floor. *Ah! ça Mais . . . arriverons-nous bientôt? . . .* (Fig. 34) rivets our attention to the floor. Improbably, yet assuredly, hugging the planking with its bewhiskered chin, there appears a human head, bespectacled, topped with a high hat. The conundrum is no sooner stated than solved, but, in that split instant, that sight has made us forget the normalcy of the setting. We are under the roof of an apartment house in the days when five floors and an attic counted as a skyscraper. A would-be renter, out of



Fig. 34. Ah! ça Mais . . . arriverons-nous bientôt? . . . (Delteil 1610).



breath, apparently has switched in his climb from stairs to a ladder. At last his eyes are level with the mansarded garret. The concierge, for once, seems apologetic.

Le Président de la diète . . . (Fig. 35), a political cartoon whose subject would call for a learned historical footnote, concentrates our attention upward. A variant of the classical plight of Damocles, it shows the diplomat comfortably seated at a table, yet most uneasy, as two swords, lethally sharp, hang by threads over his head from the ceiling. At least this is what we think we see. Facts are otherwise. Daumier totally skips any representation of the ceiling, unless one accepts the routinely ruled horizontal line that tops the image as its schematic equivalent. Nevertheless, our preconception that this invisible ceiling supports the weight of two hanging swords gives it a solidity, hence a reality, that no crayon work, however detailed, could equal. As a successful device to focus our attention, this one ventures further into the minimal than even keyholes or peepholes. As drawing goes, this ceiling is less than a dot, it is literally nothing.

Cube begets cube

Uccello created a timeless image of a cube of air encased in an architecture (Drwg. C). Vittore Carpaccio, in his *Dream of Saint Ursula*, treats with equal clarity the theme of a cube set within a cube. Once a mural panel part of a decorative ensemble, Carpaccio's presentation is heavily caparisoned in Renaissance trappings. These should be visually bypassed the better to savor the essential simplicity of the composition. In a palatial hall stands a sumptuous bed, its rectangular canopy held high by four columnar bedposts. One would expect curtains to shield the sleeper, but the painter, keen on story-telling, wants us to know that, at that very moment, Saint Ursula lies in bed, lost in a prophetic dream. To that purpose, curtains are omitted, exposing her in virginal slumber as if she were a living relic encased in a crystal cube. Story-telling aside, the bed, its six rectangular planes punctiliously parallel to the walls, floor, and ceiling, stands as a cubic solid set amid a cube of space (Drwg. D).

The stage on which Daumier props his personages is limited in length, width, and depth, a box lying on its side, open toward the spectator. Only once have we seen this cube of space bare (Fig. 28). Each subject, as a rule, calls for a distinct backdrop and related accessories.

Fig. 35. *Le Président de la diète ou le double Damoclès!* (Delteil 3507).



Fig. 36. *Yeux noirs, front haut, teint brun, barbe, favoris . . . c'est bon! on te reconnaîtra . . .* (Delteil 79).

Never visually verbose, Daumier refrains from strewing bric-a-brac as a realistic pretense. With a sense of geometrical fitness rooted in tradition, he pairs, whenever feasible, cubic solids with cubic space.

Since the fifteenth century, Carpaccio's bed had shrunk in size. The Paris bourgeois laid himself to sleep in a—by our standards—bed-size bed. By now, the canopy was a mere topknot that gathered the bed curtains into a tent shape. If Daumier is to be believed, in



Carpaccio

D

these rather shapeless recesses playlets were nightly performed, as disarmingly simple as those he watched, seated among moppets, at the Champs-Élysées.

Only in these most conservative of institutions, state hospitals run by nuns, had the antique types of bed, geometrically valid, survived. *Yeux noirs, front haut . . . on te reconnaîtra . . .* (Fig. 36) is a Carpaccio shorn of all superfluous ornaments. The hanging curtains, the bare walls, go straight to the marrow of the classical theme, a cubic solid set within a cubic space. Though soberly stated, the tale Daumier tells is not a whit less fabulous than the one Carpaccio told. We watch the king of the French, Louis-Philippe in person, jotting down the characteristics of a wounded opponent of his reign, the better to deliver him, on his return to health, to the mercies of his secret police.

A table is basically a cube. Old Masters knew it who significantly lengthened the tablecloth, thus rendering visible its four vertical planes. Often enough Daumier sketches the interior of drawing rooms and restaurants, furnished, naturally enough, with tables for his personages to



Delteil 1274

CE QU'ON APPELLE DÎNER AU RESTAURANT.

Delteil 1274

Fig. 37. *Ce qu'on appelle dîner au restaurant. Garçon! . . . voila une heure . . .* (Delteil 1274).

sit at and act their skit. The crayon stroke is curvise and casual, the characterizations witty. To insist that many of these genre scenes are, at the marrow, abstract would seem pedantic parlance. Yet it may be worth our while to probe along these lines. This we will do by comparing two drawings, similar and yet dissimilar, both having to do with tables.

For the *Charivari*, Daumier drew in the usual upright format *Ce qu'on appelle dîner au restaurant . . .* (Fig. 37). Table, tablecloth, a corner of the dining room, waiters and diners bespeak a sharply retentive memory seasoned with a dash of laughter.

Daumier worked at times for rival periodicals. The *Journal Amusant* called for a quite distinct format, an elongated rectangle laid horizontally. *Plus qu'un point! . . .* (Fig. 38) features a table, but it is now a billiard table seen lengthwise, its felt-covered top barely raised off the ground on stubby legs. The room too has suffered distortion. It is now a hall, low-ceilinged, so elongated that its lateral walls remain out of sight. Seated along the back wall and facing us, billiard lovers doze or watch the peripetes of the game. In the foreground two

LES JOUEURS DE BILLARD, — par H. DAUMIER.

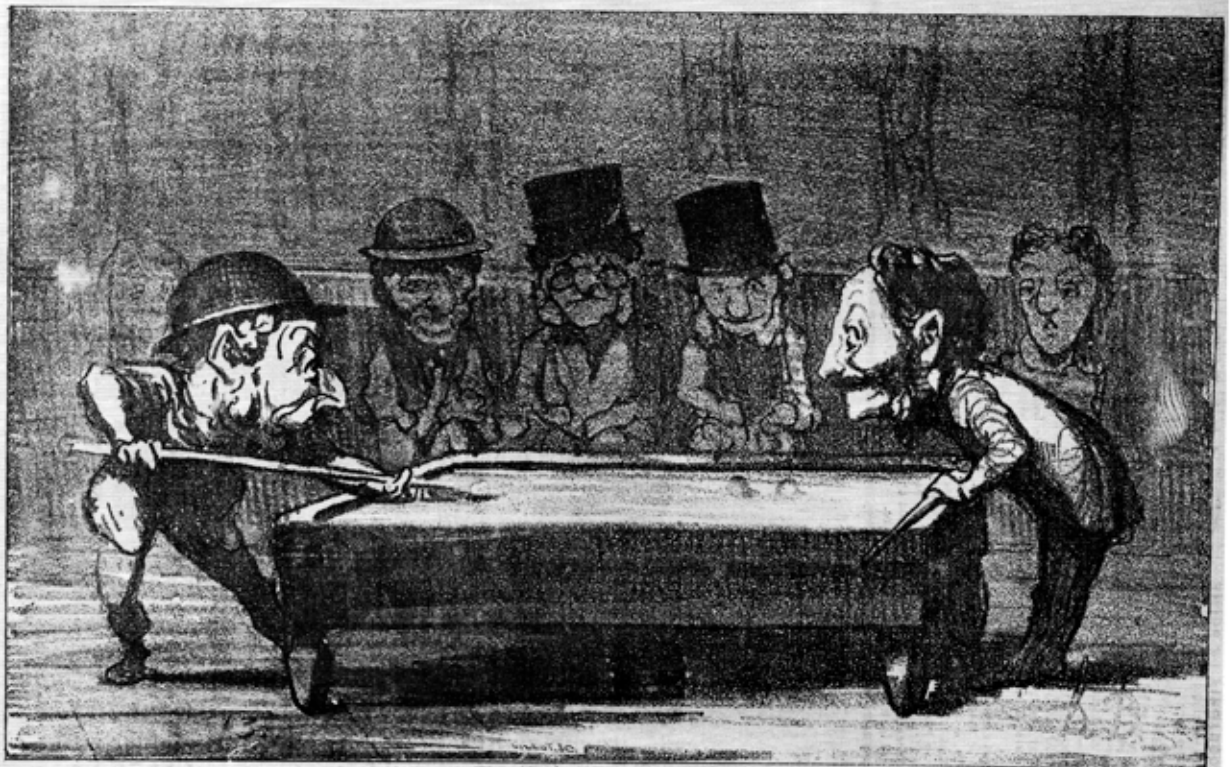

— Plus qu'un point!... et une vraie paire de lunettes... pas de chance!!

3405

Fig. 38. *Plus qu'un point! . . . et une vraie paire de lunettes . . .* (Delteil 3405).

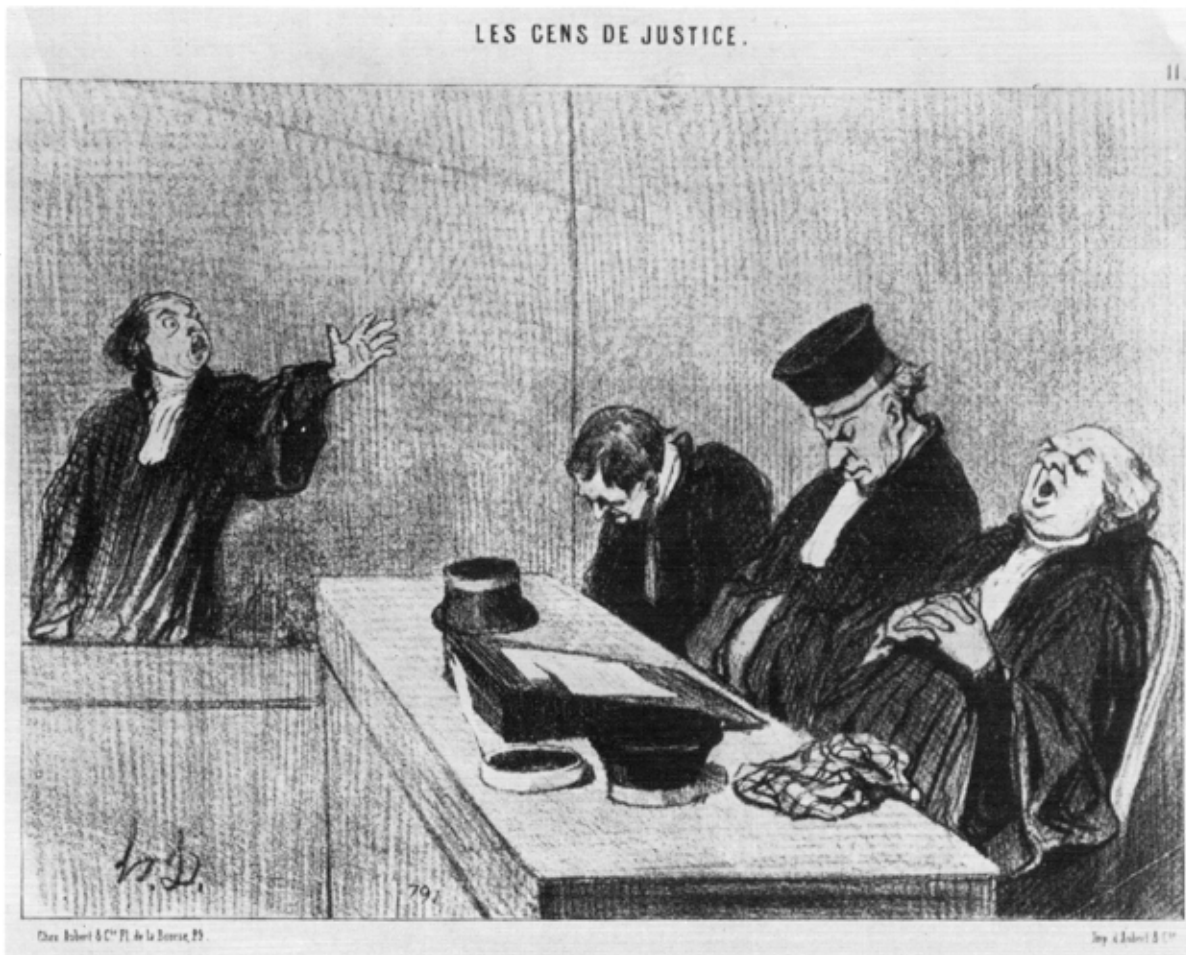

Fig. 39. *Oui, on veut dépouiller cet Orphelin . . .* (Delteil 1347).

players, cues in hand, face each other over the length of the board.

Pairing these two scenes proves instructive. When Daumier works for the *Charivari* verticals are features; horizontals for the *Journal Amusant*. Architecture, furniture, people even, all bend to the law that the distinctive formats state.

In the fifteenth century there was in Milan a monastic wall, gigantic when compared with the vignette of the *Journal Amusant*, but quite similar in its proportions. Contemporaries tell how Leonardo stood transfixed, gazing at it so often and so long that his patron, the prior, raged at his apparent laziness. To compare da Vinci's *Last Supper* with a Daumier cartoon may seem tactless only for those unacquainted with the genesis of true artistic creation. Both Daumier and Leonardo allowed the unusual proportions of each of the given areas to dictate its own solution, a frieze of personages half hid behind the horizontal of a table top running the full length of the low-lying rectangle. From then on, their paths separated. Da Vinci wrestled with God, Daumier donned his fool's cap.

In his teens a lawyer's jack-of-all-trades, jailed for the crime of lese majesty in his twen-

ties, young Daumier had had opportunity aplenty to measure the authority that a highback chair set behind a high bench confers on a judge, and how the formality of a boxed-in platform adds to the oratorical and physical gymnastics of both prosecutor and defender. Cubic in essence, this courtroom furniture was a good match for the basically cubic hall of law. These and similar adolescent musings were to bear rich fruits in later years. *Oui, on veut dépouiller cet Orphelin . . .* (Fig. 39) emphasizes the rigidity of the law by the use, exceptional for Daumier, of a ruler to draft with truly straight lines the carpentered paraphernalia.

Because interior scenes include furniture as one of the requirements of story-telling, the presence of beds, tables, or benches in pictures cannot be pointed to as a proof that Daumier juggles with cubes in a game of geometry. However, when he amalgamates dissimilar objects to conjure the image of a cubic solid, his goal, be it conscious or instinctive or both, is to echo in depth the rectangular format of the image. *Requiescat in Pace!* (Fig. 40) is a brutal image drawn in the 1870s when to failing eyesight was added a coarse semimechanical printing that did away with subtleties. In it Daumier the

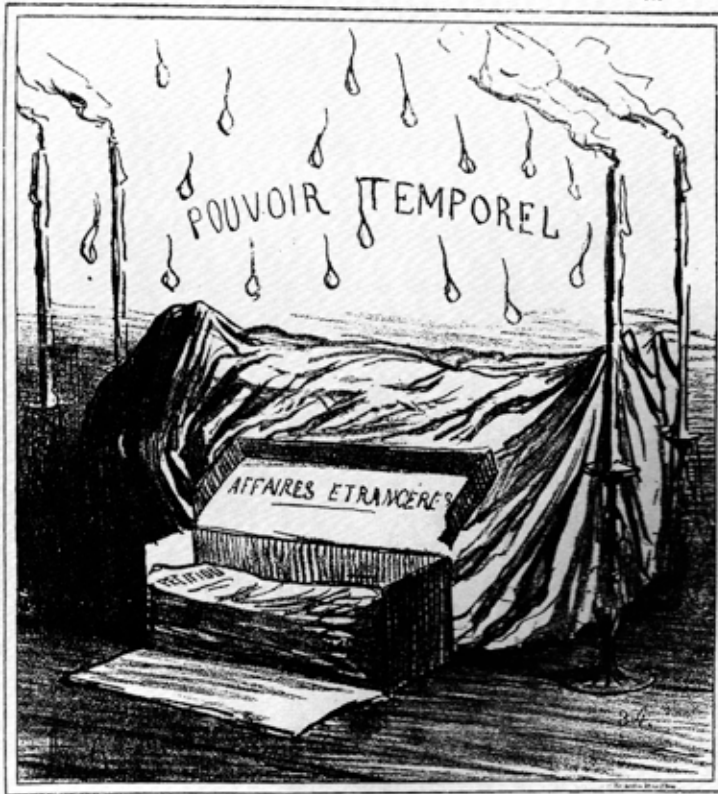

REQUIESCAT IN PACE!

freethinker acclaims the annexation of the remaining Papal States to a recently unified Italy. In the foreground an embassy dispatch trunk, its lid open, its documents exposed in a rectangular pile, suggests steps ascending to what should be a throne. Instead, it leads us to a corpse totally hid under the folds of a shroud and stretched over a morgue slab. At its four corners stand four mortuary tapers, an incongruous parallel to Carpaccio's four columnar bedposts. High tapers and high bedposts alike delimit in space a cubic shaft. There is a difference, however. Carpaccio's bed is a glorified piece of furniture. Daumier's catafalque made of disparate elements projects in space the image of a cube only because he willed it so.

Hinged motions

A cube transformed into a room acquires accessories, hinged doors, hinged windows, mobile in that they can be shut or open. This fact may have suggested to Daumier a switch from static to dynamic manipulations of space. Some of them bring into play doors or windows, while others reach hesitantly toward a world of absolutes. Though varied, these dynamic devices

Fig. 40. *Requiescat in Pace!* (Delteil 3871).



Fig. 41. *Attends, attends, j'te vas en donner moi du maitre d'école!* (Delteil 1448).

Fig. 42. *Brigand de propriétaire . . . qui ne veut me faire faire des réparations . . .* (Delteil 1605).

may be basically diagrammed within a cube, one whose six sides are hinged, able to swing inward or outward in multiple combinations.

In *Attends, attends, j'te vas en donner moi du maître d'école!* (Fig. 41) a schoolmaster pushing open the door of the classroom surprises a small student seated at the master's desk, aping his mannerisms. An amusing skit, but, as happens so often with Daumier, intertwined with another, more detached, level of thought. As if to atone for the cluster of picturesque accessories and wealth of facial expressions, the door through which the schoolmaster enters is treated in shorthand, two ruled verticals, a nearly abstract rendering. That door functions in fact as one of the lateral facets of the cube, caught in inward motion.

Dynamic effects need not borrow, as does this one, from mobile accessories. A similar result is obtained by banking on the fact that the viewer anticipates the sight of an orthodox cube. Superposed on this preconceived image, the actual drawing, in essence cubic, will forcefully deviate in one essential part. *Brigand de propriétaire . . .* (Fig. 42) presents us with the inside of a room. As expected, its floor is horizontal, its walls vertical, but its ceiling slants perilously (Drwg. E). To the left, it has already

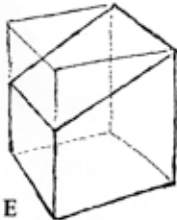

dropped halfway to the floor! A catastrophe, until we notice that this is an attic, tucked under the slope of a mansard roof, its ceiling built on an oblique. Nevertheless, that first instinctive reaction that "the sky is falling down" bathes in an atmosphere of geometric unease the very real plight of the tenant holding an open umbrella under the leaking roof, the gist of the story-telling.

To the hinged top of the cube dropping inward answers the rising up of its base to a diagonal position. In realistic terms, to the swing downward of the attic ceiling corresponds the slope upward of a flight of stairs. Daumier used



Fig. 43. *Grand escalier du Palais de justice. Vue de face* (Delteil 1372).

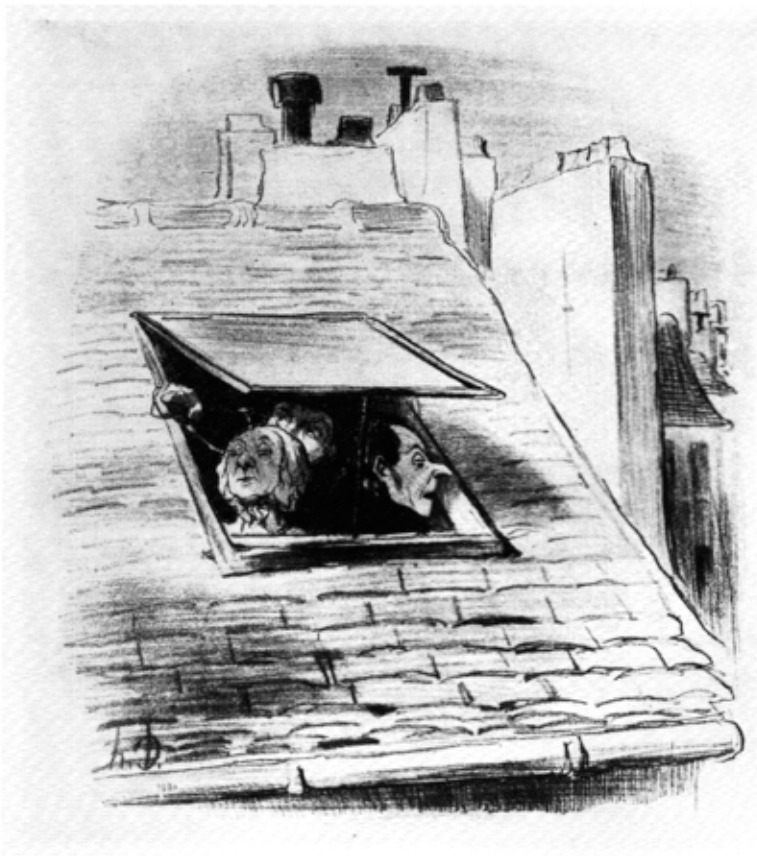

Fig. 44. *De ce côté-là vous voyez la tour Saint-Jacques la Boucherie! . . .* (Delteil 1603).

stairs to great effect in staging his playlets. In an apartment house, the staircase is his favorite meeting ground between landlord and tenants (D. 1613), and his favorite battleground between tenants and janitor (D. 1626). In public buildings stairs act monumental. A masterpiece, *Grand escalier du Palais de justice. Vue de face* (Fig. 43), seen in strictly frontal view, acquires majestic overtones. Displayed on a series of ascending horizontals, black-robed lawyers descend from the heights as did angels on Jacob's ladder. The abstract diagram is of utmost simplicity. Hinged to the lower edge of the vertical picture plane, the horizontal "floor" plane has revolved upward approximately thirty-five degrees. As was the case with the rain-drenched attic, the motion is illusive, the diagonal being set by the architect to instill in laymen contemplating the building a sense of awe at the majesty of the law.

De ce côté-là vous voyez la tour Saint-Jacques la Boucherie! . . . (Fig. 44) is based on the identical scheme displayed in three-quarter view. Hinged to the base of the picture plane, the "floor" plane of the cube has moved upward to a diagonal position (Drwg. F). However, while abstract and realistic elements dovetailed easily in the preceding example, here they part company. The hinged base of the cube has material-

ized into a roof! The skylight, raised even further than the slope of the major diagonal, acts as a small canopy over the severely restricted area where humans, or rather their disembodied heads, act and speak their skit. Thus freed from any role in the story-telling, the plain diagonal of the tiled roof acquires classical clarity.

Space represented (a) and space implied (b)

The dynamics involved in the preceding examples all occur within the confines of the basic cube. These inward motions emphasize the strictness of the cubic concept. At times, Daumier, wishing to escape from this spatial cage, will drop clues beyond these boundaries, either implied or explicit. In that sense, even a keyhole postulates unseen annexes to the primary cubic form. In *Effet de lunes* (Fig. 25) an open window becomes a triptych framing a limitless night sky.

Neither merely implied nor openly displayed, Daumier created, besides a series of forceful devices that leave us no choice but to mentally annex to the primary cube, an additional space that may be referred to as secondary. A first example introduces a rather abstract concept set within the everydayness of a bourgeois home.

Les Cabotins (Fig. 45) features a mirror before which a self-satisfied amateur applauds his own theatricals. But a mirror does not meekly reflect. It also holds magical properties, as Lewis Carroll's Alice found out when, boldly crossing over its threshold, she entered a room equal in every dimension to the one she had left behind. Frills aside, our primary cube—the room—theoretically duplicates itself on the other side of the mirror, thus doubling the span of the diagram. Correctly, Daumier situates the mirror at a right angle to the picture plane to be shared, recto and verso, by these Siamese twins, the primary cube and its reflected counterpart (Drwg. G).

Daumier is a master at enticing participation

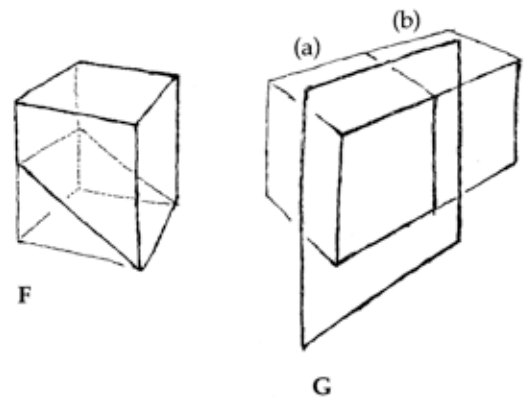

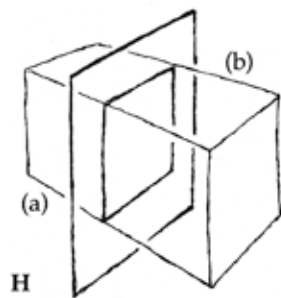

from the viewer. The janitor bent double at a keyhole tries our patience as we wait for our turn to see what he sees. More rarely, Daumier will catch our interest by a refusal to proffer clues, as in *On dit que les Parisiens . . .* (Fig. 46). Seen in strict frontal view, spectators crowd a theater pit, a sea of faces seemingly stretched to infinity. The pit is in darkness, only its first rows erratically lighted by the glow of the footlights. The play is on, all spectators are smiling. Thus, right ahead of the theater pit, if we are to believe what we see, the stage, wings, and greenroom raise their cubical architecture. In fact, I, the viewer, am on stage, my lines unrehearsed. Are they laughing with me or at me!

The motif of the twin cubes, first met in the preceding examples, is repeated here, but with a major variation. In *Les Cabotins* (Fig. 45), the mirror, set at a right angle to the picture plane, tied primary and secondary cubes into a diagram laid in pure profile. The mirror is replaced here (Fig. 46) by the picture plane, located where the stage curtain would fall. It links the crowded pit, receding in depth, with the stage and its adjuncts, jutting forward, enclosing within their ectoplasmic architecture the very locus that the viewer occupies. Thus, the device of the linked cubes is repeated, but turned around in a bold ninety-degree rotation (Drwg. H).

In 1840, King Louis-Philippe, in a move to refurbish his tarnished popularity, engineered the return of Napoleon's ashes from Saint Helena. Parisian crowds gawked as the monumental hearse draped in funereal violet made its slow progress under the Arc de Triomphe and down the Champs-Élysées. For permanent shelter an open crypt was planned, to be built in the Chapelle des Invalides where Louis XIV once had worshiped. Twelve sculptured Victories set in a circle would forever stand guard facing the sarcophagus of dark porphyry.

Before construction could begin, a crater-sized excavation was dug. Never a friend of kings or emperors, Daumier felt the moment propitious for a personal comment. *Le futur monument de Napoléon aux Invalides . . .* (Fig. 47) contrasts the classical dignity of the chapel with a disingenuous version of the work in course. Daumier often had raised a laugh by grafting giant heads on dwarf bodies, but here

LES CABOTINS (dessins inédits), de DAUMIER.



Fig. 45. *Les Cabotins* (Delteil 3949).

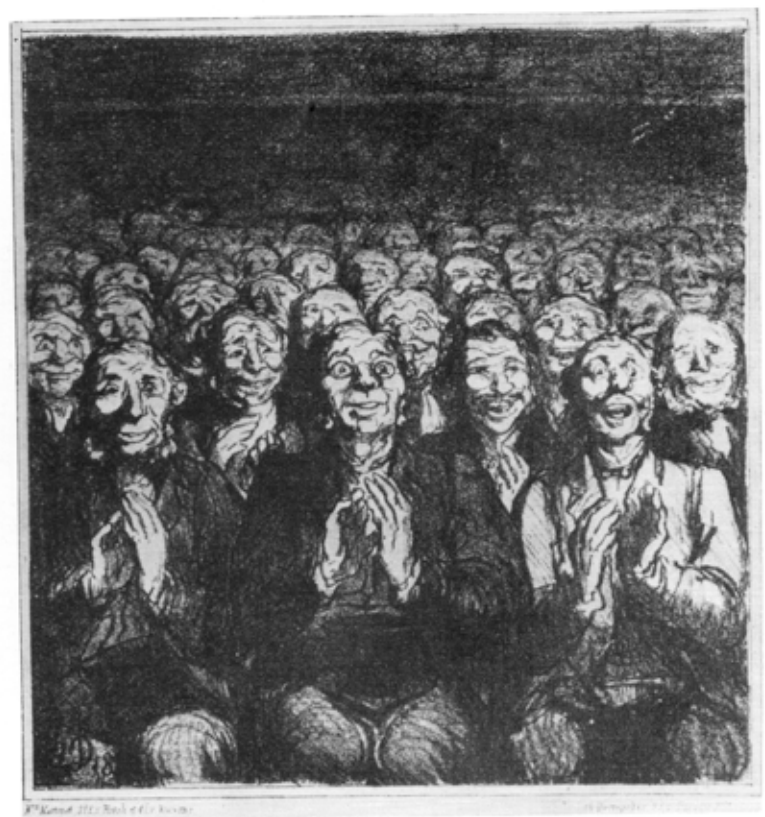

Fig. 46. *On dit que les Parisiens sont difficiles à satisfaire . . .* (Delteil 3263).



Fig. 47. *Le futur monument de Napoléon aux Invalides. Voici l'entrée de la Chrille . . .* (Delteil 981).



Fig. 48. *Examinant le nouveau plafond peint par Delacroix au Louvre* (Delteil 2228).

the comic effect is obtained by shrinking the majestic scale of the circular crypt to the size of a manhole, its lid gingerly raised by a peg-legged veteran acting as a guide. Bent double, visitors squint, attempting to pierce the darkness underfoot.

The chapel is the primary cube. The crypt is the secondary space, cylindrical in shape. Correcting Daumier's witty but unjust distortion of scale, the area shared by cylinder and cube is a circle inscribed into the square (Drwg. I). Both the diagrams of *Les Cabotins* and *On dit que les Parisiens* spread horizontally. Here the primary cube—the chapel—and the secondary cylinder—the crypt—are threaded on a vertical, the spectator's motion pointing downward.

Examinant le nouveau plafond peint par Delacroix . . . (Fig. 48) takes us to the Louvre and the Galerie d'Apollon, named after the Sun God in fawning allusion to Louis XIV, Roi Soleil. The decoration of the gallery, begun in the mid-seventeenth century by Charles Le Brun, the king's own painter, had remained incomplete for two hundred years. Astonishingly, given the norms of officialdom, its completion was entrusted to Eugène Delacroix, most controversial among living artists. His painted ceiling was unveiled in 1852.

A ceiling has already played a major role in *Le Président de la diète . . .* (Fig. 35), but it was located within the limits of the picture area. Here we deal with a hall two hundred feet in length with a ceiling raised to a corresponding height. To keep the diagram in proportion, the vertical walls of the primary cube are prolonged upward, creating a rectangular shaft, its height twice that of the cube, topped by a horizontal "lid" that reaches the level of Delacroix' ceiling (Drwg. J).

While *Le futur monument de Napoléon . . .* (Fig. 47) funneled the interest of all participants, bent double, downward, here art critics and art lovers alike bend backward, all eyes focused heavenward.

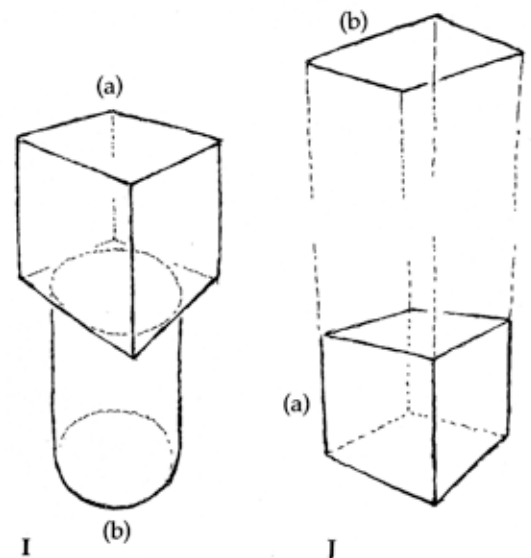

Of staircases

Daumier's graphic repertory borrowed its strength from sets and accessories that, for the Parisian of his day, acquired rich meaning through their undiluted everydayness. Early in our century the cubists were to do the same for their Paris, that was no longer Daumier's. In their still lifes, the pipe comes out of their pocket. From the package of tobacco they fill the pipe. On the match holder they scratch the match that lights the pipe. The newspaper, they peruse as they smoke.

Daumier's restricted visual vocabulary lacks even this mild bohemian flavor. Though he was not totally a bourgeois—the genius must have had its lodgings somehow inside him—he was as unmitigated an addict of the bourgeois as was Pieter Breughel, who was no peasant, of the peasant.

In Daumier's graphic work, staircase motifs loom large. Elevators were not in use, and climbing stairs for the Parisian a daily must. The ascent started with a mild ceremonial gesture, the wiping of feet on the mat plus a short dialogue with the ever-watchful concierge. Then began a sort of safari for the home-bound, the loss of plumb and the spiraling ascent. The staircases Daumier drew evoked in the nineteenth-century viewer reactions not merely visual. The palm of the hand gliding against the coolness of the bannister, the leg muscles reenacting their path upward and round about, the mild vertigo of a glance down the stairwell, the key noisily fumbling into the lock and at last, stability recovered, the change to slippers, the fireplace, the peace. While the self-contained interiors could be duplicated as stage sets, these spiral motions encircling a column of nothingness transcended theatrical make-believe. Daumier welcomed this dare to his creativeness. Let us compare two subjects, both related to the start of the ascent.

Ma femme est-elle à la maison? . . . Oui m'sieu . . . (Fig. 49) presents a strict profile view of the stairs, their thrust upward roughly dividing the image in two triangular areas. The female concierge stands lower left, her proprietary stance underlined by a broom firmly grasped. The ascending lodger, half hid behind the oblique of the ramp, fits tightly at the upper right, his high hat pushing against the edge of the picture area.

L'Oubli de la consigne (Fig. 50) illustrates the identical scene caught full front. The stairs, represented by their superimposed uprights, fit along a vertical with just a trace of a spiraling torsion, then stop as they reach the horizontal landing. Seen from the back, the tenant takes



Fig. 49. *Ma femme est-elle à la maison? . . . Oui m'sieu . . .* (Delteil 1650).



Fig. 50. *L'Oubli de la consigne* (Delteil 1626).

the steps two by two, his off-balance emphasized by a violent foreshortening of the doubled-up left leg and the elongation of the right, the tip of its shoe still touching a lower tread. As before, the janitress is set plumb, stiff as her broom handle. Her index finger points to the mat at the foot of the stairs that the fellow, in his naiveté, had hoped to bypass.

These two identical episodes, one caught in strict profile and the other full front, could have been snapped simultaneously by two cameras set ninety degrees apart. At the start of his career, Daumier would model lumps of clay into the semblance of politicians that, from then on, remained at his mercy from whatever angle was needed. The procedure was not unusual. For his entry to the Salon of 1819, Géricault had had carpentered a reduced model of the raft of the *Medusa*, topping it with wax figures. In mid-career, however, Daumier, hurried and harried by deadlines, lacked leisure for such niceties, but the mental habit remained. Comparing both lithographs makes us realize with what conviction he grasped in depth the positioning of his personages within an architectural setting.

Checking the surface patterns exclusively, these two lithographs (Figs. 49, 50) seem totally

unrelated. Disregarding the distinct sighting angles, however, a single diagram describes both. The lobby is the primary cube. The apartment implied at the level of the landing fills the secondary cube. The schema may be started with two equal planes bisecting each other in the shape of a Greek cross, their width that of a cube, their length twice their width. One half of the horizontal plane locates the ceiling of the lobby, the other half the level of the landing. The vertical plane similarly performs a split purpose. Its upper half stands for the frontage of the second-floor apartment, its lower half for the back wall of the lobby. Once completed, the diagram ties on an oblique the primary and secondary cubes, as dictated by the diagonal of the stairs (Drwg. K).

We have seen how effortlessly Daumier glided from factual reporting into a realm of utter fantasy. Barrels piled by lumpers on the quays of Bercy (Fig. 3) motivate a quizzical landscape strewn with barrels, each housing a disgruntled Diogenes (Fig. 4). The sketch of fashionables promenading at the Tuileries (Fig. 7) inspires the tumbling earthward of pretty parachutists clothed in the new fashion (Fig. 8). Daumier's staircase motifs, so realistically conceived that one could argue the use of three-dimensional

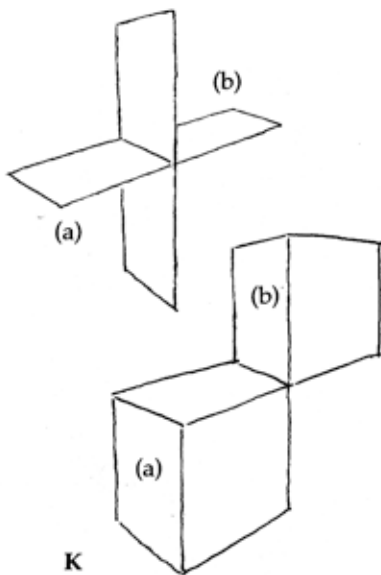

Fig. 51. *Les Parisiens à Cherbourg*.—Eh! bien . . . nous ne sommes pas déjà trop mal . . . (Delteil 3062).

models, lent themselves to a similar metamorphosis.

Les Parisiens à Cherbourg . . . (Fig. 51), drawn on a hot August day, spans the gap between realism and surrealism. Come summer, Parisians left for the country, and the well-to-do flocked to seaside resorts. In mid-century provincial inns offered the only shelter available to the vacationer. When the few rooms were filled, beds crowded the corridors, tents spotted the lawns. Indeed the local inhabitants, left throughout the winter to their own meager resources, felt no compunction whatever in making hay while the sun shone.

If we are to believe Daumier, even staircases were put to profitable use, each lodger being allotted an individual step. In *Les Parisiens à Cherbourg*, two men in night attire attempt sleep on such Spartan beds. Their clothes hang on pegs. For furnishings, a candle, a washbasin, a water jug. "Place for six roomers more," adds the caption. Thus the gist of the story-telling. Our specialized interest focuses here on the smoothness with which Daumier has transformed the tawdry staircase into a fabulous architecture. It spirals upward without visible support and without visible end, reminiscent of the ribbon of bronze reliefs that wraps itself diagonally around the Trajan Column, Daumier's classical favorite.

Art and folk-art sources of motion

Though the present study does not feature the usual art historical comparisons, mapping the climate that surrounded Daumier will help us place his work in perspective. His relationship to the Barbizon School, friendly if puzzled, has been touched upon, as well as his lyrical use of chiaroscuro for ends distinct from those of the realist school. As regards neoclassicism, what followers of Jacques-Louis David were still active had settled into routine teaching, striving to instill in schoolboys, plumbline in hand, the awe they felt at the sight of plaster Apollos, fig leaf and all (D. 1468). Though Daumier, in his cartoons, burlesques their cult of the antique, the thoughtful orderliness distilled out of his own compositions is proof enough that an unassuming classicism was indeed one of the ingredients of his complex style.

However, most "modern" art went another way. Following Delacroix, romantic rebels waved high their colorful banner. Had Daumier's oils been better publicized, he might have been counted one of them. Not that his graphics lean that way. When the vagaries of foreign politics brought Morocco into the headlines, Daumier sketched *mamamouchis* straight out of Molière, sucking on a narghile pipe and shaded by a dilapidated umbrella, indeed a far

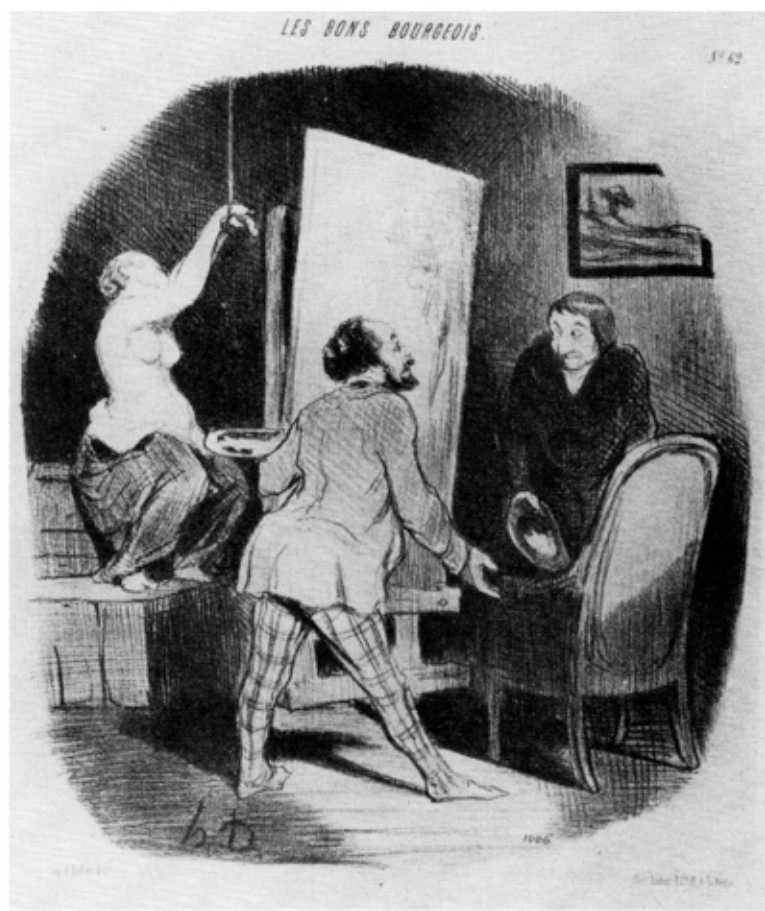

Fig. 52. *Entrez donc, monsieur . . . ne vous gênez pas . . . c'est un tableau vivant! . . .* (Delteil 1538).

cry from Delacroix' *Moresque magic* (D. 1327). Nevertheless, unlike the balanced compositions we have studied, there are others, based on a willful disequilibrium, that show Daumier adapting to his own ends the dynamics that romantics favored. His preferred subjects, street scenes, artisans at their work, precluded the possibility of posed models. In his graphics he mocked colleagues who, with a system of cords and pulleys, froze the live model into postures meant to suggest motion (Fig. 52).

The flagstone pavement that David had set unyielding under the feet of the Horatii symbolized for neoclassical artists an immutable order. Newcomers, rating fluids over solids, chose to set their episodes on ever unstable waters. Literally so, be it the Styx on whose swift current Delacroix precariously launches Dante's skiff, or the high seas shredding to bits the raft of the Medusa and its load of derelicts. *Victor Hugo et Emile de Girardin cherchent à élever le Prince Louis* . . . (Fig. 53) mimics, not unkindly, Géricault's masterpiece. Wracked by political tempests, the future Napoleon III precariously attempts a sailor's stance on the tiniest of rafts.

Daumier's aversion to the picturesque limited the range of his dynamic ventures. His colleagues searched far and wide for heroic, tragic,



Fig. 53. *Victor Hugo et Emile de Girardin cherchent à élever le Prince Louis . . .* (Delteil 1756).

or poetic subject matter. Daumier remained content with the sights, noises, smells even, of the Paris he loved. Tired of walking he would climb on the omnibus, memorizing its motley array of passengers and, more to our point, the vagaries of its inner architecture. At stops, the upright of the jambs, the row of rectangular windows, the arched ceiling evoked stability. On the go, thanks to rusty springs, reluctant horses, and unpredictable street pavements, coach and passengers alike suffered a metamorphosis, shaken up and down, thrown to the right and to the left. *Intérieur d'un omnibus . . .* (Fig. 54) sets the plight of the damsel in such an architecture in motion. Its verticals mimic diagonal postures, its horizontals shift like the sea—until the next stop, when a more classical order of things shall, for at least a moment, prevail.

The hand puppets of the Champs-Élysées had taught Daumier gestures more telling in their staccato simplicity than those of live actors, a knowledge he memorized and used to quicken the grasp of the readers of *Le Charivari* on his graphic story-telling. Besides, tools in

LA CARICATURE PROVISOIRE.



Fig. 54. *Intérieur d'un omnibus. Entre un homme ivre et un charcutier* (Delteil 566).

daily use furnished him with patterns of mechanical motion. The grocer, the butcher weighed their goods on a pair of scales. At times the bourgeois, but more often his cook, basket in hand, watched closely the arm of this simple machine as it hovered hesitantly along diagonals, until both scales, their weight equalized, returned it to the horizontal. Daumier lifted this commercial tableau to a symbolic plane. One of the few lithographs that an ever-alert censor, smelling a shift in the political winds, rejected, it shows giant scales wherein the French Republic, a statuesque matron, outweighs a bunch of reactionary plotters (untitled, Delteil 2000, as *Suffrage universel*) (Fig. 55).

A nursery commonplace, the seesaw, motored by playful children into a sort of perpetual motion, inspired Daumier. *La Balançoire turco-russe* (Fig. 56) adapts it to headlines. Set on top of the pediment of this Temple of Mammon, *La Bourse*, a turbaned Turk and a Russian in furred hat keep the seesaw going to the dismay of puzzled investors.

Nouveau Joujou dédié par Ratapoil . . . (Fig. 57) taps an even humbler source. Since at least the eighteenth century, street peddlers hawked penny toys that today we would title "mobiles." Constructed of painted sticks moved by moppet power, two wrestlers wrestled, or two



Fig. 55. *Suffrage universel* (Delteil 2000).

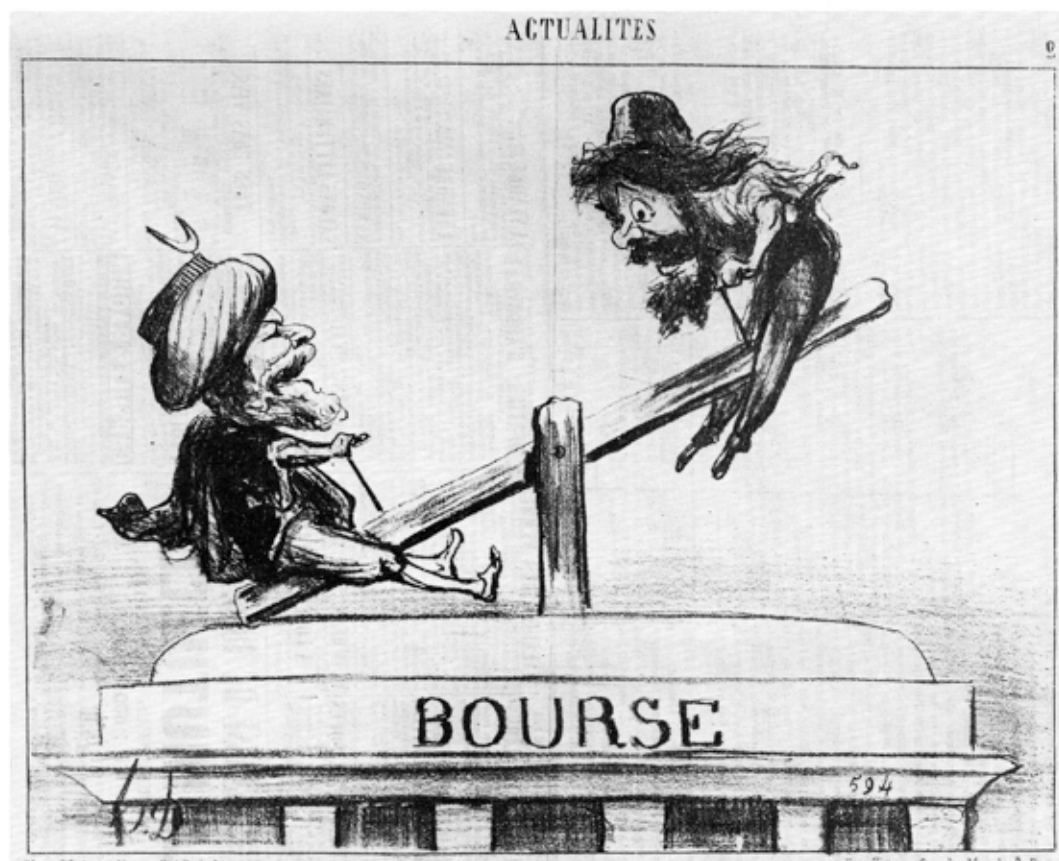

Fig. 56. *La Balançoire turco-russe* (Delteil 2506).



Fig. 57. *Nouveau Joujou dédié par Ratapoil . . .* (Delteil 2158).

smiths, face to face, hammered at their forge. Here Ratapoil, his mustache bristling upright not unlike demon's horns, is the toy hawk. *En lieu* of smiths, evil politicians, each armed with Guignol's own bludgeon, administer to the French Republic an endless bastinado.

Dynamic composition

To illustrate Daumier's fluctuating understanding of motion as an aesthetic means, we may compare two lithographs identical as to subject matter, drawn twelve years apart. In 1833, Daumier was in his mid-twenties and already well known, partly for his metamorphosis of the features of King Louis-Philippe into a pear, a visual prank that eventually put him in jail. *Le Bois est cher et les arts ne vont pas* (Fig. 58) dates from that same year. It is winter. In their studio two artists perform a joyless dance as an alternative to freezing. The story-telling is childishly explicit. A musician holds tight to his violin, while behind his music sheets are displayed on a stand. The painter, as he dances, hugs his loaded palette, brushes, and mahlstick. An open paintbox, an unfinished canvas set on an easel leave us in no doubt as to his vocation! The studio itself is overstuffed with bric-a-brac. On the walls, plaster casts, prints,

Fig. 58. *Le Bois est cher et les arts ne vont pas* (Delteil 146).



Fig. 59. *Quant on a brûlé son dernier chevalet* (Delteil 1334).

pictures. On a shelf, a potiche and a bust. On the floor made of rotted planking stand a plaster torso, a cold food warmer, dirty dishes. In the time it takes us to make this inventory the legs and arms of the personages, though angled to imitate motion, become weighted into motionlessness by such a load of anecdotal storytelling.

Quant on a brûlé son dernier chevalet (Fig. 59) is a second version of the identical subject. Drawn twelve years later, with the added experience of twelve hundred lithographs between, it shows how Daumier's ideas have evolved. As stated in the caption, all wooden stuff—furniture, easel, violin even—has been fed to the cylindrical stove. Factually a logical step and as well a pictorial boon, for the studio is now free of bric-a-brac. A single unfinished painting, mural in scale, leans against the whitewashed wall. The cold stove angles its pipe toward the ceiling. The two artists, as before, dance to avoid freezing, but now have plenty of knee and elbow room to move in. This second version seems a shorthand rendering of the first, but it is more than that. Instead of a dynamic



Fig. 60. *Le Carcan* (Delteil 105).

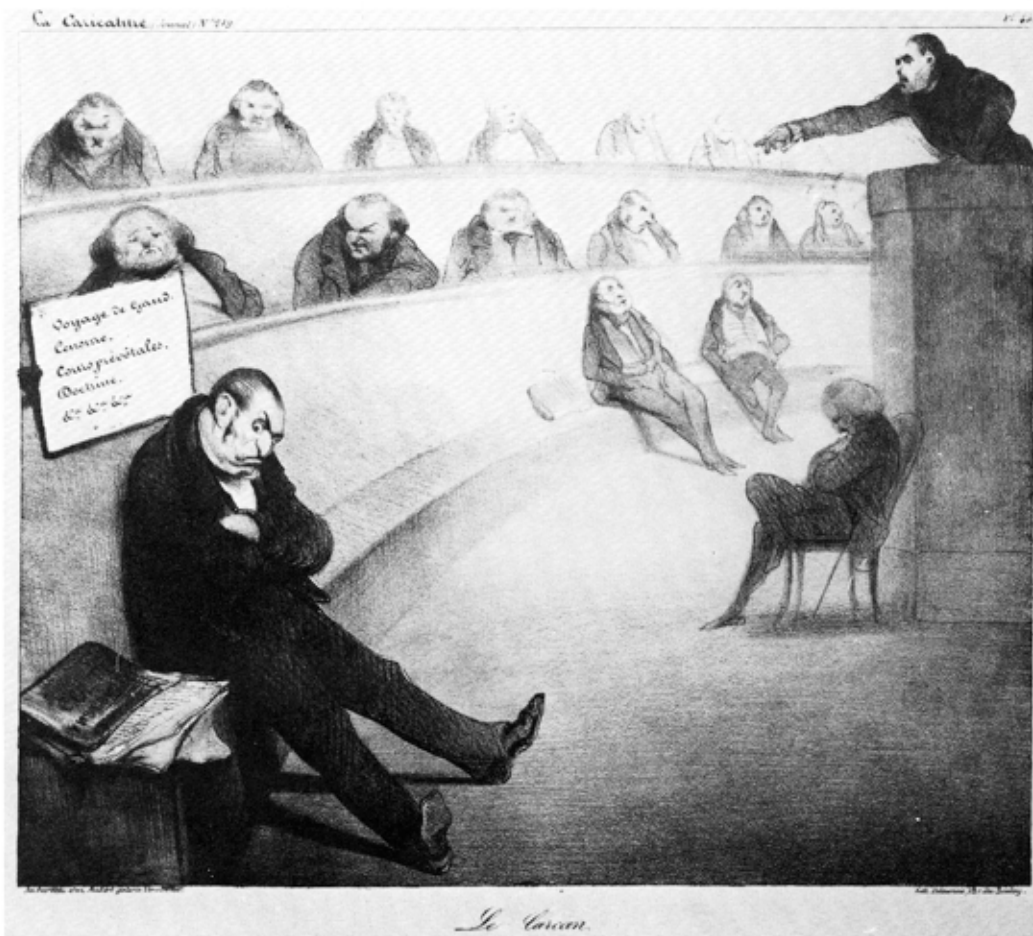

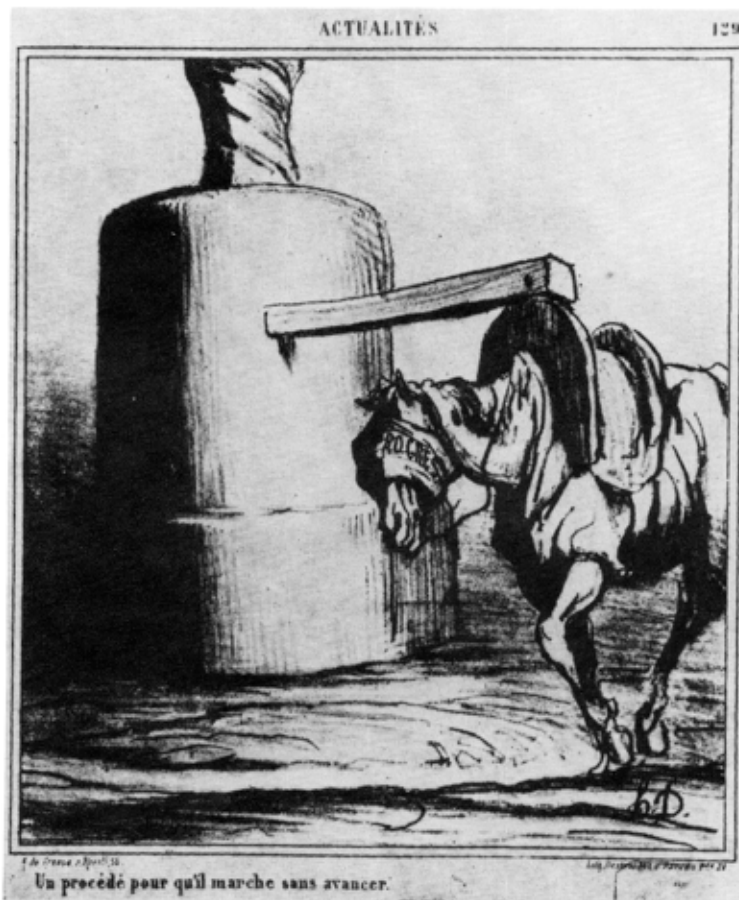

Fig. 61. *Un Procédé pour qu'il marche sans avancer* (Delteil 3645).



subject matter stifled by a static composition, subject matter and composition are now equally dynamic. The large painting leaning against the wall could be understood as the rectangle of the image area tipped off balance. The stovepipe propped against the upper corner of the image opposes its obtuse angle to the right angle of the border as if the latter had been disarticulated and set loose. Chiaroscuro, in the first version realistically rounding each object, acquires now a life all its own, its strokes the trails of the motion of Daumier's hand at work. Not only the humans, but the objects, canvas, stove, areas of light and dark, the animate and the inanimate, all dance!

In the preceding examples motion has been, in varying degrees, a consequence of the subject matter. The pair of scales, the seesaw, the penny toy, though lifted to a symbolic plane, were borrowed straight out of daily realities. The second version of the pair of studio scenes activated abstract relationships of lines and angles as an accompaniment to the human pantomime. Though it would be pleasant, given the taste of our time, to map Daumier's progress from realism to abstraction on the strength of these two studio scenes, facts are otherwise. Our next example, dissociating still further composition from subject matter, dates in fact from his early days as a cartoonist.

Le Carcan (Fig. 60)—as does Daumier's better-known masterpiece *Le Ventre Législatif*—pictures a meeting of the Chamber of Peers. In both prints the hemicycle is spattered with seated politicians, some impassive, some dozing so deeply that, as far as human motion is concerned, the whole could pass for a waxwork display. Caught in frontal view, *Le Ventre Législatif* is eminently static. *Le Carcan*, focusing on the same scene from the side, features the hall itself, summing up the stepped-up rows of benches as concentric segments of circles with the speaker's podium as their common center. The strong set of perspective curves flows forward with such force that, leaping over the edges of the image, it spreads far and wide, suggesting a giant roulette wheel in motion. As drawn, the story is static, the composition dynamic.

Un Procédé pour qu'il marche sans avancer (Fig. 61), a late "Gillotage," includes a similarly circular motion as part of a clumsy piece of machinery, a stone mill. A blind Rosinante named Progress, harnessed to the handle of the grinding stone, plods dispiritedly along a circular track, her slow tempo contrasting with the swift flow conjured in *Le Carcan*. Though perpetual motion is the gist of the story, the composition remains static.

Fig. 62. *Les Trains de Plaisir. Quand après dix assauts infructueux . . .* (Delteil 3295).

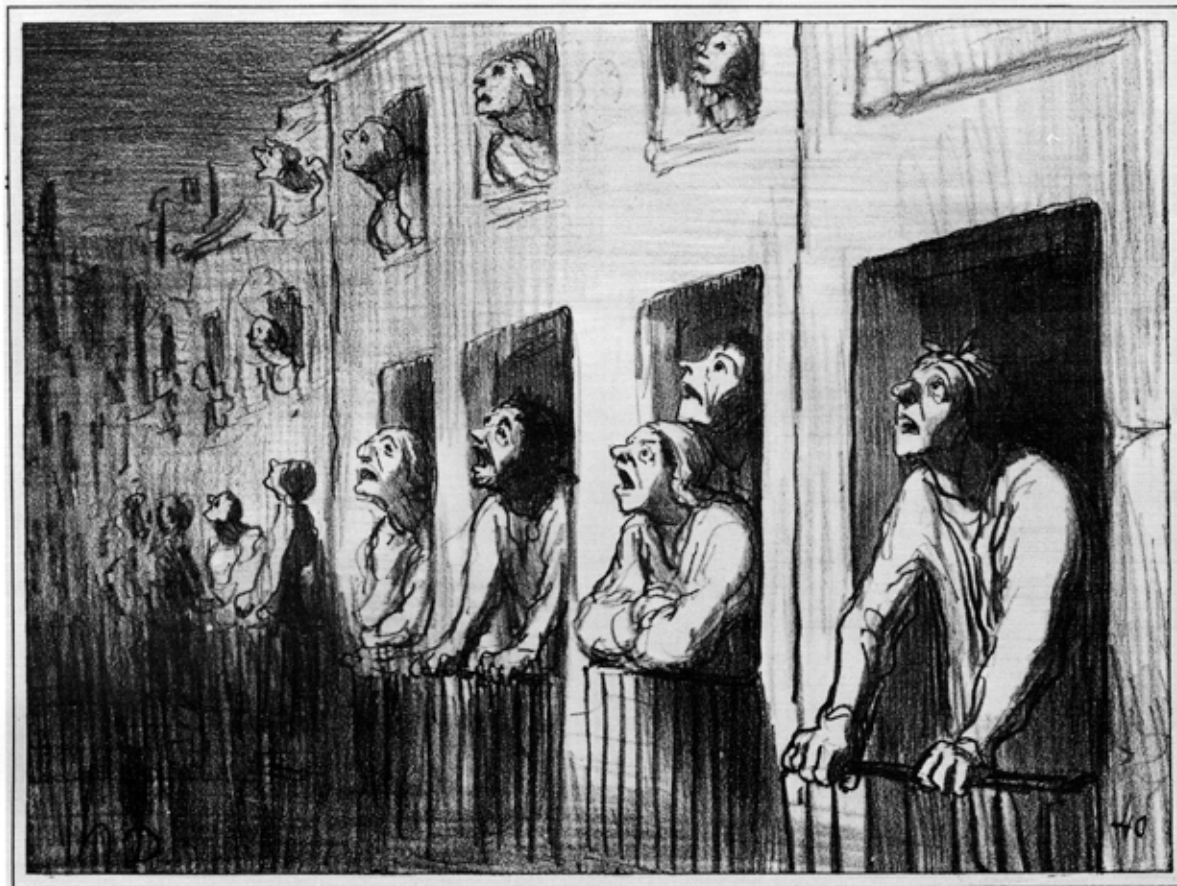

Fig. 63. *Aspect que commencent déjà à avoir chaque soir les rues . . .* (Delteil 2931).

Toward infinity

Most of Daumier's compositions even, as we have just observed, when they involve circular motion, cover limited areas. Daumier's landscapist friends had all freedom to put between them and the segment of nature they fancied such distance that even the hastiest of sketches encompassed vast vistas. Conscious of being one ant in the human ant hill, Daumier had neither the ways nor the wish to insulate himself from his models in this fashion. Observation at close range spelled a close composition. In his scarce sorties out of these chosen limits he cautiously refuses to discard those familiar figures, the rectangle and the cube.

Les Trains de Plaisir . . . (Fig. 62) deals with city dwellers overcrowding so-called pleasure trains, the quicker to escape summer's stifling heat. The low line of sight makes the assaulted train loom formidable, yet, on analysis, what Daumier has drawn is little more than a receding series of doors opening on the compartments, a set of parallel rectangles diminishing in scale, drawn a bold black in the foreground and modulated, according to the laws of aerial perspective, to delicate grays as they recede, or so it appears to us, into infinity.

Daumier's other standard unit, the cube, stands throughout his graphics as the basic summary for a Paris apartment. *Aspect que commencent déjà à avoir chaque soir les rues . . .* (Fig. 63) aligns side by side and piles on top of each other these symbols of the Parisians' tenuous privacy. For each unit dwellers rush simultaneously to identical balconies, hoping for a first glimpse of the comet that is making headlines. The magic of aerial and linear perspective stretches this dismal sight even further than the length of a Paris street, ad infinitum.

In England, in the 1840s, J. W. Turner in *Rain, Steam and Speed* had portrayed the newly harnessed steam power as an iron steed belching soot, a locomotive noisily straddling a peaceful Thames. Equally awed by this dubious invention, Daumier hints more gently at its destructive power. In *Oh! Le gueux . . .* (Fig. 64), as the iron monster surges over the horizon, a hunter watches impotently the imminent destruction of the hare he has just shot and who chose to die over the steel tracks. So unswerving are the bare perspective lines rushing straight at the viewer that one imperceptibly moves sideways to escape a similar fate.

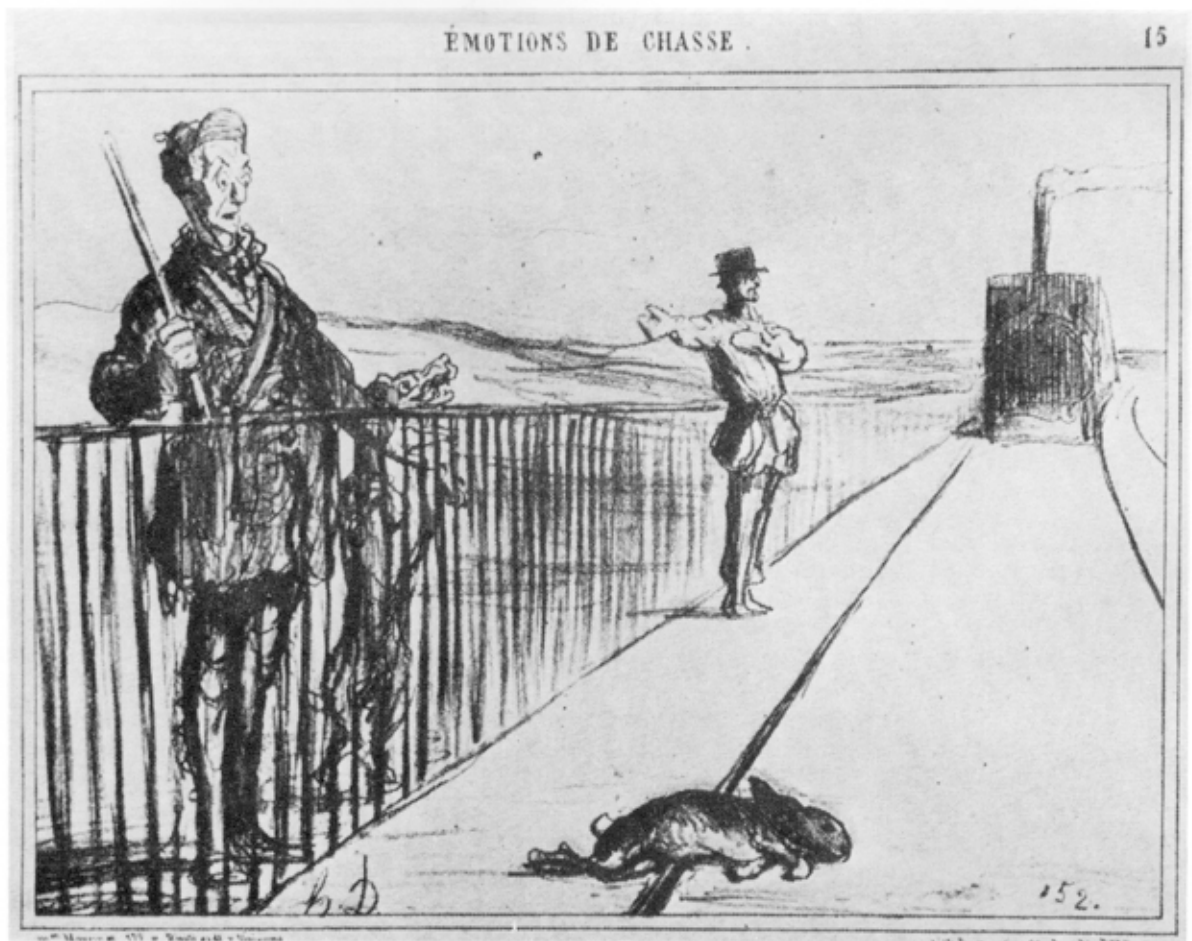

Fig. 64. Oh! Le gueux . . . il a été mourir là exprès . . . (Delteil 2889).



Fig. 65. Position réputée la plus commode pour avoir un joli portrait . . . (Delteil 1525).



Fig. 66. *Souvenirs* (Delteil 579).



Fig. 67. *Comment se termine, après dîner, une conversation conjugale* (Delteil 1498).



Fig. 68. *Prison royale—Entrée—Sortie* (Delteil 209).

Varied approaches to time.

Even before the mid-century, Daumier, who could not even in a portrait detach form from motion or motion from time, felt uneasy at the potential of yet another invention, the daguerreotype. *Position réputée la plus commode pour avoir un joli portrait . . .* (Fig. 65) parallels his satirical sketch about painters who, with a system of ropes and pulleys, froze the nude model into a pose meant to depict action (Fig. 52). Here the racking with stems and screws that the sitter patiently endures to win pictorial immortality is funny, but unfunny is the goal of the wizard draping himself within the machine. As his chemical brews acquire potency, the photographer will reduce the time of pose to little or nothing, and thus snap totally unnatural images of man disconnected from time's flow, with all traces of motion eliminated.

The daguerreotype was part of a concerted assault on dynamic mysteries that would better have been left alone. Scientists disturbed time's

flow in yet another way, by clocking phases of motion so minutely that a past action could be artificially reanimated. From the 1830s on, primitive forms of cinematography were worked into toys, the phenakistoscope that revolved vertically, the zoetrope that revolved horizontally. His eye fixed to a minute lookout, the viewer watched birds in flight, balls bouncing, frogs jumping. Boys pedaled their velocipedes, girls skipped rope. Such a timing of motion by the clock clashed with Daumier's idea of a time that quickened or slowed down according to man's moods. The passionate oratory of a prosecutor, flailing space with as many arms as a Hindu god, hurried time. Evenings, time slowed to a stop when the bourgeois, dropping his newspaper to the carpet, dozed. In the lithographs, Time dons varied masks. A time clocked by the calendar, as the Old Year slinks away and the New Year 1842 is joyfully greeted (D. 976). It may be time remembered, as the aged roué lulls himself to sleep contem-

plating the portrait of his young mistress, young that is when rococo was in its prime (Fig. 66). Not even hinted at in the caption, time is wordlessly present as a well-fed couple in well-padded armchairs, resting their hands over their bellies, sit under portraits, his and hers, that resembled them twenty years ago (Fig. 67).

A drastic manipulation of time is featured in an early pen-and-ink lithograph, *Prison royale—Entrée—Sortie* (Fig. 68). Compositionally it remains unique in Daumier's work in that it presents the primary cube sideways, its corner jutting forward within the rectangle that frames the image. The jail building looms menacingly like the prow of a dreadnought of stone. On the left the prisoner enters. On the right he leaves, a corpse boxed in a pauper's coffin. What happened in between, boredom, starvation, sickness, despair, is left out. All intermediate episodes, in film parlance, have been strewn on the floor of the cutting room. Only these two

moments, initial and terminal, are seen spliced together.

Jean Charlot (1898-1979) worked as a liturgical artist and writer in Paris before moving to Mexico in 1920. There he worked as a printmaker and painted the first monumental fresco in modern times, which became a technical, thematic, and stylistic influence on the Mexican mural renaissance. He also worked as an archaeologist and wrote extensively on all periods of Mexican art history including the first article on José Guadalupe Posada.

Moving to the United States in 1930, Charlot continued his work as artist and scholar, teaching at several universities. In 1949, he moved to Hawaii, where he produced murals and monumental sculpture in several media and wrote on various aspects of Hawaiian culture and history.